

Shouldn't we make biochemistry an exact science?

By Bob Eisenberg

Exact science is useful. The physics of X-rays is exact. Biochemists can trust X-ray crystallography, because the equations of X-rays are exact. But we rarely trust the equations that describe our own experiments, and that is for good reason. The equations fail so often. Biochemists know that the law of mass action we use every day is not exact. The rate constants of that law change as conditions change. When we try to use that law, we must change parameters, but we do not know how. The law of mass action is not exact and not very useful, because we often cannot transfer it — parameters unchanged — from one set of conditions to another. This fact is known to every enzymologist, but sad to say, other scientists often are not aware of this reality.

Biochemists have tried to make their theories exact by increasing resolution. Our models of enzymes include thousands of atoms in cathedrals of structure. The hope has been that computing all the atoms of those cathedrals would produce exact simulations, if not exact equations. But as the calculations of molecular dynamics reach from atomic to biological scales, we face disappointment once again: Enormous resolution does not guarantee useful biological results.

We know very well that most enzyme reactions are controlled biologically by trace concentrations of ions like Ca^{2+} . No atom simulations are large enough, however, to deal with the 55 M water that dis-

solves each calcium ion. The atomic resolution of simulations will have limited use if we cannot deal with the trace concentrations that control enzymes in health and disease.

I argue here that exact equations have not been possible because mathematics has not been available to deal with the interactions that occur in ionic mixtures like seawater. Biology occurs in modified seawater, and changes in ion concentration change the reactions of most enzymes. All the ions in seawater are linked by the electric field. Many are linked by steric interactions as well. Some are linked by orbital delocalization of electrons shared with water or other molecules (i.e., chemical bonds). Exact theories in biochemistry must use the mathematics of interactions.

These interactions are not small effects

Most biological ionic solutions, like seawater, are far too concentrated to behave like ideal fluids or electrolytes even without chemical bonding. They are, in fact, complex (not simple) fluids.

The free energy per mole (the experimental quantity called the activity of an ion, extensively measured in the literature) is the simplest property of an electrolyte. Activity plays a role something like height in a gravitational field and voltage in an electric circuit. In seawater, the activity of the bio-ions Na^+ , K^+ , Cl^- and Ca^{2+} does not vary linearly

with concentration (as in an ideal fluid) or even with the square root of concentration (as in extremely dilute solutions of NaCl).

Interactions and nonideality are not small effects, because ions are highly concentrated where they are most important: in and near active sites, ion channels, binding proteins and nucleic acids; near the working electrodes of electrochemical cells; at charged boundaries in general. There, concentrations are often more than 5 molar, and solution properties are dominated by interactions. The activity of one ion depends on the individual concentration of every other ion. Everything interacts with everything else. Some of the interactions usually called allosteric may in fact arise in the highly concentrated solutions in and near active sites of proteins.

The mathematics of interactions has been understood for a very long time when the systems involved are conservative and do not involve friction. Hamiltonians and variational calculus are the language of high-energy physicists when they build their bright X-ray sources.

Hamiltonians have not been used in most biological systems, because biology occurs in condensed phases where friction is always present. Until recently, no one knew how to use Hamiltonians in systems with friction. Friction accompanies all ionic movement and conformation changes in biology, because atomic collisions occur on a 10^{-16} time scale in solutions. That is why

Charge is an abstraction with different physics in different systems.

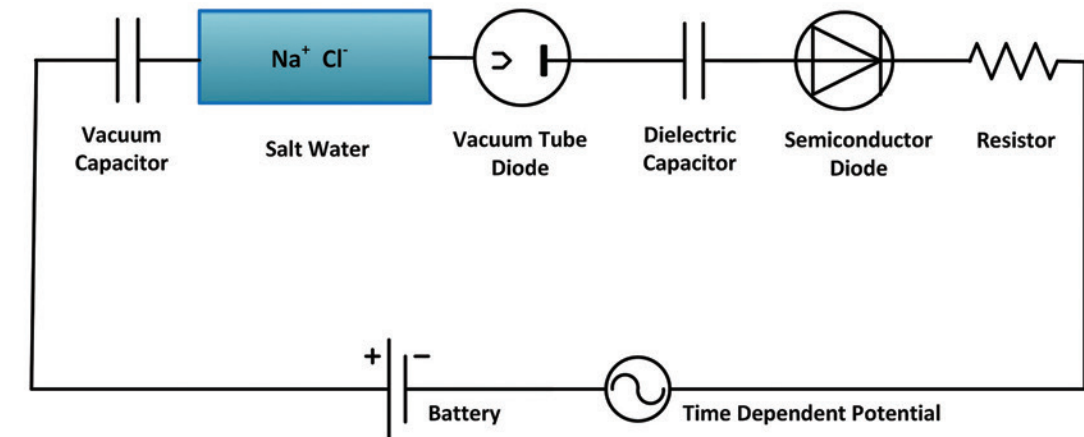

solutions are called condensed phases, and only three or four collisions are enough to convert deterministic motion into the random motion we call heat.

Theory of complex fluids

Recently, mathematicians have developed a theory of complex fluids that generalizes Hamiltonians into an energetic variational calculus dealing with friction. The theory has had striking successes.

Variational methods deal successfully with liquid crystals, polymeric fluids, colloids, suspensions and deformable electrolyte droplets that fission and fuse including the interfacial properties such as surface tension and the Marangoni effects of oil on water and tears of wine. It is a little early to say the theory of complex fluids provides exact equations in general, but the theory certainly provides a productive pathway toward that goal.

The perspective the variational calculus offers is striking even if its results are immature. Complex fluids must be analyzed by variational methods, because everything interacts with everything else. If those interactions are not addressed with mathematics, the interactions are bewildering, and the results cannot be analyzed. A mathematics designed

to handle interactions is needed to produce exact equations. Otherwise, interactions vary in so many ways that fixed parameters cannot deal with them.

Life at equilibrium is usually death

Biochemical systems always involve ionic solutions in which the electric field links everything with everything else. Exact equations must be consistent equations in which all the variables satisfy all the equations and boundary conditions in all conditions.

In particular, the electrical forces and potentials must be computed from the concentrations of all charges present — in solution, in macromolecules and in layers near boundaries — because those electric forces can change qualitatively and quantitatively when charge changes anywhere.

The equations of electricity are global. The flow of charge at one location changes the flow everywhere. Flow must be dealt with consistently in biochemistry, because life does not occur without flow. Life at equilibrium is usually death.

Charge is an abstraction

The global dependence of the electric

field is glimpsed in the cartoons of Kirchoff's current law used in computational electronics. But Kirchoff's law is so intertwined with Maxwell's exact equations of electricity that they are inseparable.

The key idea in Maxwell's theory is charge. Charge is abstract. Charge changes its physical nature as it flows through a circuit (see figure). It is electrons in a vacuum tube; it is ions in salt water; it is quasi-particles in a semiconductor; and it is nothing much (i.e., displacement current) in a pure vacuum. Yet the flow of current is the same in every element in a series circuit, although the physical nature of that current is strikingly diverse.

The global nature of electric flow prevents the law of mass action from being exact. The law of mass action — with rate constants that are constant — does not know about charge. Its rate constants do not depend on charge in a way that guarantees Kirchoff's current law (as shown in the supplementary material at <http://arxiv.org/abs/1409.0243>).

The law of mass action is about mass conservation. It is not about charge conservation. The laws of electricity guarantee the current will be the same for all reactions in a series. The law of mass action does not.

CONTINUED ON PAGE 38

CONTINUED FROM PAGE 37

How do we make changes?

How can we fix this problem and remake our laws so that they deal well with interacting systems and electric charge? I do not know a general answer, but I know where to look for help.

Physicists for years have used consistent analysis of flow and diffusion of charges to design transistors for devices. Those devices have increased in capability by billions in 60 years, and that striking success may have something to do with the exact laws that those devices follow.

I believe biochemistry can add to its own substantial successes of the past 60 years by trying to make its laws exact. If the spatial dependence of the electric field is built into a new version of the law of mass action, we surely will do better than we have done in understanding how enzymes, channels and nucleic acids do their work.

Consistent treatments will not be easy

Giving up inconsistent treatments will be like giving up part of our intellectual heritage.

We can no longer look the other way when rate constants vary. We must use activities, not concentrations, to describe reactants in crowded active sites when studying allosteric interactions. We no longer can compute fluctuating concentrations of charge and assume electric fields do not fluctuate. We must learn to deal with fluctuating electric fields in our treatments of Brownian motion of ions so that results will not seem so anomalous.

We must incorporate boundary conditions and finite-size ions into the law of mass action. Algebra and ordinary differential equations must give way to field theories, partial differential equations and variational calculus.

We must even incorporate spatial inhomogeneities and electric fields into our treatments of covalent chemical reactions in ionic solution, because those spatial inhomogeneities are likely to produce very large local concentrations lasting long enough that reactions occur quite differently from reactions in a spatially uniform

system.

We cannot just calculate models with higher and higher resolution. We must compute consistently with the electric field, on all scales, with theories appropriate for each scale.

Mathematics is now available

Mathematics is finally available to deal with diffusion and electric fields in a consistent way, and the theory of complex fluids and simulations of computational electronics have shown that mathematics can describe complex fluids and devices (nearly) exactly. Now let's try that mathematics on the classical problems of biochemistry to see if we can construct a consistent theory of reactions that is exact and useful.

A fully cited version of this paper and supplemental figures and materials are on the arXiv at <http://arxiv.org/abs/1409.0243>.



Bob Eisenberg (beisenbe@rush.edu) is chairman of Rush University Medical Center's molecular biophysics and physiology department

The Florida Biomedical Career Symposium

November 7, 2014

www.asbmb.org/careersymposia

KEYNOTE SPEAKER:

Sir Harold W. Kroto

Co-recipient, 1996 Nobel Prize in Chemistry
Francis Eppes Professor
Department of Chemistry and Biochemistry
Florida State University

KEYNOTE LECTURE TITLE:

The Global Educational Outreach for
Science, Engineering and Technology
(GEOSET) Project Pioneered from
Florida State University

Supported by The Scripps Research Institute,
Florida and the American Society for
Biochemistry and Molecular Biology Career
Symposia Program

