

THREE-DIMENSIONAL ELECTRICAL
FIELD PROBLEMS IN PHYSIOLOGY

by

ROBERT S. EISENBERG AND EDWARD A. JOHNSON

Reprinted from

PROGRESS IN BIOPHYSICS AND MOLECULAR BIOLOGY

Volume 20

Editors: J. A. V. Butler and D. Noble

PERGAMON PRESS—OXFORD & NEW YORK

1970

THREE-DIMENSIONAL ELECTRICAL FIELD PROBLEMS IN PHYSIOLOGY

ROBERT S. EISENBERG† and EDWARD A. JOHNSON

*Department of Physiology and Pharmacology,
Duke University Medical Center,
Durham, North Carolina*

CONTENTS

PREFACE	3
PART A. PHYSICAL INTERPRETATION AND MATHEMATICAL ANALYSIS	
I. INTRODUCTION AND GENERAL OUTLINE OF THE PRESENTATION AND APPROACH	5
I.1. <i>Introduction</i>	5
II. THE ELECTRICAL FIELD AROUND CURRENT SOURCES AND ONE- DIMENSIONAL CABLE THEORY	6
II.1. <i>The Electrical Field around Current Sources</i>	6
II.2. <i>Steady-state One-dimensional Cable Theory</i>	9
III. SOLUTIONS OF THREE-DIMENSIONAL ELECTRICAL FIELD PROBLEMS FROM SOLUTIONS OF ANALOGOUS HEAT PROBLEMS	13
III.1. <i>General Discussion</i>	13
III.2. <i>Conversion of the Solution of a Heat Problem to the Steady-state Solution of an Electrical Problem</i>	16
IV. THE CYLINDRICAL CELL	18
IV.1. <i>Solution of the Three-dimensional Cable Equation</i>	18
IV.2. <i>Determination of a Convenient Expression for the Roots</i>	21
IV.3. <i>Computation of the Spread of Potential</i>	24
IV.4. <i>Plots of the Spread of Potential</i>	25
IV.4a. <i>Both electrode tips just beneath the membrane</i>	25
IV.4b. <i>Both electrodes deep in the cell</i>	32
IV.4c. <i>One electrode just beneath the surface and the other deep</i>	32
IV.5. <i>Universal Figure and Table</i>	35
IV.6. <i>Appendix: Approximation to the Roots β</i>	37
V. THE SPHERICAL CELL	38
V.1. <i>Solution of the Spherical Problem</i>	38
V.2. <i>Approximations Used in the Spherical Problem</i>	39
V.2a. <i>Approximations to the roots</i>	40
V.2b. <i>Approximations in the infinite series</i>	40

† Present address: Department of Physiology, UCLA School of Medicine, Los Angeles, California 90024. Some of the later work, done at this address, was supported by U.S. Public Health Service Grant HE11351. The earlier main part was supported by USPH08620.

VI. THE THIN PLANE CELL	41
VI.1. <i>Solution of the Thin Plane Cell</i>	41
VII. THE THICK PLANE CELL	45
PART B. QUALITATIVE DESCRIPTION AND PHYSIOLOGICAL IMPLICATIONS OF THE THREE-DIMENSIONAL SPREAD OF CURRENT IN CELLS	
I. DISCUSSION APPLICABLE TO ALL CELL GEOMETRIES	46
I.1. <i>The Approximate Nature of One-dimensional Theory</i>	46
I.2. <i>The Single Electrode Bridge and Double-Barreled Microelectrodes</i>	49
I.3. <i>Voltage Gradients in Extracellular Space</i>	54
I.4. <i>Voltage Clamp with Two Microelectrodes</i>	55
II. THE CYLINDRICAL CELL	56
II. 1. <i>The Optimum Electrode Separation within a Cylindrical Cell</i>	56
III. THE A.C. CASE	59
III.1. <i>A Brief Description and Derivation of the Generalized Frequency- dependent Length Constant</i>	59
IV. THE SPHERICAL CELL	63
REFERENCES	64

PREFACE

THIS article is concerned with the voltage gradients within a cell that are associated with the three-dimensional spread of electrical current. We have divided the material into two sections. The first, Part A, presents a discussion of the method of solving the mathematical problem of analysing the three-dimensional flow of current within a cell. Thereafter follow detailed descriptions of the solution for a number of simple geometries of cells: the cylindrical cell, the spherical cell, the thick and the thin plane cell. The second part, Part B, is intended for the general reader and gives a qualitative description in words of some of the results and conclusions to be drawn from the analyses presented in Part A.

PART A. PHYSICAL INTERPRETATION AND MATHEMATICAL ANALYSIS

I. INTRODUCTION AND GENERAL OUTLINE OF THE PRESENTATION AND APPROACH

I.1. *Introduction*

The electrical properties of cells can be accounted for in large part by the electrical properties of the cell membrane and the cytoplasm which the cell membrane encloses. For most, if not all, cells, the electrical properties of the membrane can only be studied *in situ*. In other words, the properties of the membrane must be inferred from some observed electrical properties of the cell as a whole. Since the cell membrane defines the boundary of the cell, it can be shown that if the shape of the cell conforms to some simple geometry, the magnitude of current injected into the cell and the resultant displacement of transmembrane potential are related in some predictable way to the electrical properties of the cell membrane, namely its impedance to the passage of electrical current. How this observed relationship depends on the specific membrane resistance and resistivity of the cytoplasm has been examined theoretically for a number of shapes of cell. These shapes include the infinitely long cylinder or cable, the sphere, the thin plane cell and the thick plane cell. The theoretical treatment used for each of these geometries usually makes a number of assumptions and the necessary conditions these assumptions impose often cannot be realized experimentally. These conditions frequently involve the current source. For example, in the case of one-dimensional cable theory, the current source is ideally an infinite plane sheet, less ideally, a disc placed at right angles to the fiber axis and equal in diameter to the fiber. In practice, a microelectrode is often used and this approximates a point source of current. As we shall see, the use of such a source violates the essential assumption of one-dimensional cable theory, namely that the current flows in only one dimension, and this violation under certain circumstances causes serious deviations between the measured values of membrane potential and the values predicted by one-dimensional cable theory.

We have already mentioned that in order to determine, theoretically, the spread of potential within the cell about some sources of current, the geometry of the cell is idealized as some simple, three-dimensional shape such as a sphere, a cylinder or disc, which may or may not closely approximate the actual geometry of the cell. Nevertheless, even if one of these shapes is a good approximation, in order to simplify the mathematics, further approximation is sometimes made in that the electric field in one or more of the three dimensions of the cell is neglected. That is to say, it is assumed that the potential is constant along the dimensions of the cell that are neglected.

In the theory developed here we make no such assumptions and hence a comparison of the predictions of this theory with those of theory in which such an assumption is made shows decisively the circumstances which necessitate the use of three-dimensional field theory in solving electrophysiological field problems.

Before we describe in detail the application of three-dimensional field theory to such problems we first show in section II.1 that the electrical field near the source of electrical current depends on the geometry of the source. Secondly, in section II.2 we demonstrate, how, for example, one-dimensional cable theory cannot properly describe the spread of potential in a cylindrical cell about a point source of current.

In section III we show why and how the steady-state solution of heat field problems can be used to obtain the steady-state solution of electrical field problems. The next four sections, IV, V, VI and VII, describe in detail the derivation of equations which describe the three-dimensional electrical field about a point source of current in a semi-infinitely long cylindrical cell (section IV), a sphere (section V), a thin infinite plane cell (section VI) and a thick (infinite) plane cell (section VII). In the introduction to each section the parts that are of more interest to the general reader are pointed out.

II. THE ELECTRICAL FIELD AROUND CURRENT SOURCES AND ONE-DIMENSIONAL CABLE THEORY

II.1 *The Electrical Field around Current Sources*

The shape of the electrical field sufficiently near a small source of electrical current depends primarily on the shape of the source and is independent of the shape of the cell. The shape of the source is determined by the number of dimensions in which the source is described. This follows directly from the definition of a source mathematically (Morse and Feshbach, 1953), but perhaps the above statement can be made more plausible to the general reader by discussing several examples which bear it out.

We will calculate the field produced by simple sources in one, two, and three dimensions, namely the field about a point, line and plane source of current. Since we will only consider the effect of the geometry of the source in determining the electrical field we will consider the source and resultant field to be in a uniformly resistive material.

Point source

The illustration for the point source of current is given in Fig. II.1-1.

Consider a point source of current in a homogeneous material of volume resistivity R_i . Imagine the point source to be at the center of a sphere of radius r so that the direction of current flow through the surface of the sphere will be normal to that surface and furthermore the current density, and hence the

potential there, will be uniform over that surface. Now consider a second, slightly larger, surrounding the first, with radius $r + \Delta r$. The potential, V , over

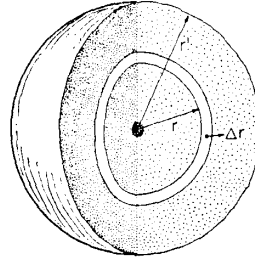

FIG. II.1-1. Point of current in a three-dimensional conductor.

the surface of the sphere with radius r , will be greater than that over the slightly larger surface of the sphere with radius $r + \Delta r$ due to the voltage drop, $-\Delta V$ across the resistance, ΔR , of the thin shell of material of thickness Δr .

$$\Delta V = \frac{R_i \Delta r}{A} \quad (\text{II.1-1})$$

where A is the surface area of a sphere, radius r ; i.e.

$$-\Delta V = \frac{i_0 R_i \Delta r}{4\pi r^2} \quad (\text{II.1-2})$$

where i_0 is the total current.

Dividing equation (II.1-2) through by Δr and taking the limit as $\Delta r \rightarrow 0$ we get

$$-\frac{dV}{dr} = \frac{i_0 R_i}{4\pi r^2} \quad (\text{II.1-3})$$

Hence,

$$V = - \int_{r'}^r \frac{i_0 R_i}{4\pi r^2} dr \quad (\text{II.1-4})$$

where r is the nearer of two points distance r and r' from the point source of current.

$$V = \frac{i_0 R_i}{4\pi} \left[\frac{1}{r} - \frac{1}{r'} \right] \quad (\text{II.1-5})$$

If the potential at distance r from the current source is measured with respect to a distant fixed point r' , so that $r' \gg r$, then

$$V = \frac{i_0 R_i}{4\pi r} \quad (\text{II.1-6})$$

that is to say the potential falls off inversely with distance from the point source.

Line source of current.

The potential close to a line source of current in a homogeneous material of resistivity of R_i can be calculated by considering the line source to lie along the longitudinal axis of two concentric cylinders of radius r and r' (see Fig. II.1-2). The current flows uniformly from the line in a direction at

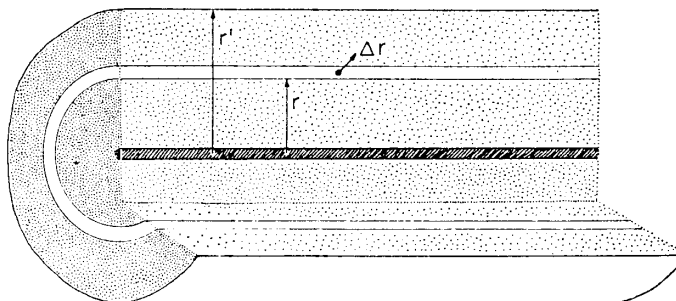

FIG. II.1-2. Line source of current in a three-dimensional conductor.

right angles to the line, the circumference of either of the two cylinders therefore delineates points which are equal distance from the line. The potential at the distance, r , normal to the line source can be calculated by considering a third cylinder concentric about the smaller of the other two but of radius $r + \Delta r$. The current, i_0 , at a distance r will be associated with a potential V , and at a distance $r + \Delta r$ with a potential $V - \Delta V$. Thus there will be a voltage drop, $-\Delta V$, caused by the current flowing through the distance Δr , that is to say, through the resistance of the thin sheath of material thickness Δr , which surrounds the first cylinder. The resistance of unit length of this sheath will be R_i divided by the area of the sheath, $2\pi r$, and multiplied by its thickness, Δr .† The voltage drop $-\Delta V$ will be equal to the product of this resistance and the current flowing through it.

$$-\Delta V = \frac{i_0 \Delta r}{2\pi r} R_i \quad (\text{II.1-7})$$

Dividing through by Δr and taking the limit as $\Delta r \rightarrow 0$ we get

$$-\frac{dV}{dr} = \frac{i_0 R_i}{2\pi r} \quad (\text{II.1-8})$$

Hence V is given by

$$V = - \int_r^{r'} \frac{i_0 R_i}{2\pi} \frac{dr}{r} \quad (\text{II.1-9})$$

which when integrated between the limits r and r' gives

$$V = \frac{i_0 R_i}{2\pi} \ln \frac{r'}{r} \quad (\text{II.1-10})$$

† Our calculation is for a unit length of the infinite cylinder.

That is to say, the potential falls off *logarithmically* with distance as opposed to *inversely* with distance for a point source. Furthermore, the potential approaches infinity as we approach the line and the point source. This is not surprising since we are forcing a finite current through a source which in each case has no area.

Plane source of current

Consider a circle of unit area on the surface of the plane source of current. Current leaving the plane sheet will be directed at right angles to the surface of the plane and will flow into a resistance, imagined as the resistance looking into the end of a slab of unit cross-sectional area. It is clear in this case that since this resistance increases linearly with the thickness of the slab, the potential will fall off linearly with distance. Since the source has area the current density through it is finite and hence, at the source, there is no discontinuity in the potential and the potential does not go to infinity.

II.2. *Steady-state One-dimensional Cable Theory*

In one-dimensional cable theory the electrical potential is assumed to vary in only one dimension so that the direction of current flow in the cable is assumed to be in one direction only, namely, along the longitudinal axis of the cable. In other words, the potential in any one cross-section of the cable is considered constant. The theory treats the inner conductor as a line along which current is flowing, the resistance to the flow of current per unit length of this line, r_i , being equal to the resistance of a unit length of the real conductor of radius, a , and volume resistivity, R_i , i.e. $r_i = R_i/\pi a^2$; R_i in [ohms] [cm⁻¹].

The inner conductor is enveloped by a semi-insulating sheath and the resultant cylindrical cable is surrounded by an outer conducting sheath, the potential of which does not change with time or distance. The specific resistance, R_m of the semi-insulating sheath is in [ohms][cm²] and the resistance of a unit length of this sheath is r_m ([ohms][cm]). If the path length from inner to outer conductor through the sheath is of insignificant length, current can be considered to flow across the sheath only in one direction; namely radially. There are three ways in which the current can flow along the inner conductor from its site of injection to complete a circuit by reaching the outer conductor. It can flow (1) through the resistance of the semi-insulating sheath, (2) through the capacitance created by the separation of the inner and outer conductors by the sheath, and (3) through some load that may terminate the cable at a certain distance on either or both sides of the site of injection of current.

This model cable is most closely simulated, biologically, by a nerve fiber where a long thin-walled cylinder of membrane imperfectly insulates an inner conductor of cytoplasm from an outer conductor of electrolyte in which the fiber is immersed. In this case, the fiber membrane is sufficiently thin to be able to neglect its thickness, so that current is considered to flow through it only in a direction at right angles to its surface. The condition that must be

satisfied for one dimensional cable theory to be applicable is that the current inside the cell flows in one direction only, namely down the longitudinal axis of the fiber. However, there are two situations where the direction of current flow obviously must have a radial† as well as a longitudinal component; one situation is in turning to leave the fiber through the membrane and the other is in entering the fiber from some kinds of current source, e.g. a point source. In both cases, deviation between the potential predicted by one-dimensional theory and measured values of the potential will occur, the magnitude of which will depend on the magnitude of the radial compared to the longitudinal component of current flow. Clearly, close to a point source, current will be flowing in all of three dimensions, that is to say, both radially and longitudinally and the deviation referred to above can be large. Voltage gradients develop about the point source of current which drive the current away from the source so that further down the fiber the entire cross-section of the fiber is filled with a uniform flow of current, of constant density in any cross-section. As we shall see, it is these radial voltage gradients near a point source of current which cause the measured potential within the fiber to deviate seriously from the potential predicted by one-dimensional theory. If one were to choose as a current source a disc placed at right angles to the long axis of the fiber and equal to its diameter (Taylor, 1963, pp. 244-6), then this kind of radial voltage gradient and the resulting errors are eliminated. In this case the current leaves the source (i.e. enters the fiber) in one direction, namely longitudinal to the fiber axis. Whether the current then maintains this direction while it leaves the cell depends only on the electrical properties of the membrane and the inner conductor and not on the source. For example, were r_m so low and/or r_i so high that most of the injected current left the fiber (via the membrane) within a distance comparable to the diameter of the fiber, then clearly the direction of current flow down the fiber at any point would have a considerable radial component. A consideration of one-dimensional cable theory allows us to assess under what circumstances the current would have to deviate significantly from its assumed one-dimensional pathway in order to leave the fiber.

From one-dimensional cable theory we have

$$V(x) = V(0)e^{-x/\lambda} \quad (\text{II.2-1})$$

where V is the steady displacement of membrane potential at a distance x from the site of injection of a steady current i_0 into *one end* of a semi-infinitely long cable, and $\lambda = (r_m/r_i)^{\frac{1}{2}}$. The longitudinal current at any point in the inner conductor at distance x from the site of injection of current is given by Ohms law, i.e.

$$i(x) = -\frac{1}{r_i} \frac{dV}{dx} \quad (\text{II.2-2})$$

† The direction of current flow in three dimensions in a cylinder is best expressed as three components of direction: one longitudinal, x , another an angle, θ , and a third a distance, r , in a plane oriented at right angles to the longitudinal axis of the fiber. Thus, current flow in a radial direction, in this case, means in any direction at right angles to the longitudinal axis of the fiber.

Using equations (II.2-1) and (II.2-2)

$$i(x) = \frac{V_0}{r_i \lambda} e^{-x/\lambda} = \frac{V_0}{\sqrt{r_m r_i}} e^{-x/\lambda} \quad (\text{II.2-3})$$

$$i(x) = \frac{V_0}{2R_p} e^{-x/\lambda} \quad (\text{II.2-4})$$

where $R_p = \frac{1}{2} (r_m r_i)^{\frac{1}{2}}$. Therefore, equation (II.2-4) says that if i_0 is the magnitude of the current injected (i.e. the value of i at $x = 0$), then at a distance $x = \lambda$ down the fiber, $i(x)$ will have a value of $i(x)/e = 0.37i_0$. That is to say, a considerable fraction of the current injected, almost two-thirds, will have escaped through the membrane as membrane current.

This distance λ in which most of the longitudinal current has escaped must be large if one-dimensional cable theory is to be applicable, since the condition required by one-dimensional cable theory is that current flows in one direction only, along the longitudinal axis of the fiber. Therefore it is necessary that the value of λ be very much greater than the radius, a , of the fiber. How much greater λ must be than the fiber radius for the predictions of one-dimensional cable theory to be valid within a given error will be found by studying three-dimensional cable theory, which includes the effects of radial current flow.

The analysis of three-dimensional cable theory given later in this paper shows that although the voltage gradients associated with the current turning to leave the fiber through the membrane can become significant, they are always of secondary importance to those voltage gradients which are associated with driving the current away from a point source of current within the fiber. The reason for this is that the circumstance which causes the current to deviate from its predominantly one direction of flow in order to leave the fiber is the same condition which causes the voltage gradients about the current electrode to become comparable with the displacement in the potential gradient across the membrane. This circumstance occurs when the effective length constant becomes comparable with the diameter of the fiber, for instance when the membrane resistance or impedance is low. In this case much of the current leaves the fiber in a distance comparable with the diameter of the fiber, but, more importantly, more current must be injected to produce measurable displacements in the transmembrane potential. Although the magnitude of voltage gradients about the electrode tip is independent of the membrane resistance; they are, however, dependent on the magnitude of the current injected (and the resistivity of the cytoplasm). Thus as the membrane resistance is decreased, two interacting factors cause the voltage gradients about the electrode tip to contribute more and more to the total potential recorded by a voltage electrode situated close to the point of injection of current. The displacement in transmembrane potential caused by a given current flowing through the membrane is decreased and secondly, since more current has to be

injected (to obtain a given displacement of the membrane potential), the voltage gradients about the current electrode are increased. Thus, these voltage gradients around the current electrode become important when the membrane resistance (or impedance) is low, i.e. when the effective length constant is small.

It must be remembered that the length constant is not really a constant since the effective resistance of the membrane (i.e. its impedance) is a function of the frequency of the injected current and indeed may depend on the value of the current. The surface membrane has both capacitive and resistive properties and when arranged in the form of a simple smooth cylinder, the impedance it presents to the flow of current is that of a resistance in parallel with a capacitance. For the steady state case where the amount of the current injected is time invariant, that is to say the transmembrane potential at any point is constant, the membrane current is purely resistive and the effective length constant λ is given by $(r_m/r_i)^{\frac{1}{2}}$, so provided that λ is very much greater than the fiber radius, one-dimensional cable theory is applicable. However, if the membrane potential at any point is changing, the membrane current has two components, one capacitive and one resistive, and in this case the spread of potential is not regulated by $(r_m/r_i)^{\frac{1}{2}}$ but by $(z_m/r_i)^{\frac{1}{2}}$, where z_m is the membrane impedance given by a complex number. This question is discussed in more detail in Part B, section III, but here suffice it to say that if alternating currents are injected, there will be some high frequency of current where the membrane impedance, z_m , is so low that the effective length constant at this frequency is comparable to the fiber radius a ; and the measurable values of $V(x)$ will deviate seriously from those predicted by one-dimensional cable theory. A similar situation occurs when the membrane potential is changing in response to a step of injected current. In this case the current and voltage waveforms are a complex mixture of a large spectrum of frequencies; the individual amplitudes and phases of the high-frequency components determine the quickly changing parts of the waveforms and the low-frequency components determine the slowly changing parts of the waveform. Each frequency corresponds to an effective space constant and since the contribution to the waveform of the different frequency components is different at different times, the effective length constant itself is a complex function of time. Thus, at short times, which correspond to high frequencies, the effective length constant becomes comparable to the fiber diameter and deviations from one-dimensional theory are important.

In the expressions for $V(x,t)$ obtained from one-dimensional cable theory, z_m (the a.c. generalization of r_m) and r_i are usually considered constant, though they need not be: these equations are of value even if z_m and r_i are functions of V , x or t , provided of course that these functions are known and that the essential assumption regarding one-dimensional flow of current is not violated. An example of the use of one-dimensional cable theory, where z_m at any x is a function of voltage and time, is in the numerical solution of the Hodgkin-Huxley equations for a propagated action potential (Hodgkin and Huxley, 1952; Cooley and Dodge, 1966). The current source in this case would appear as a ring equal in radius to the fiber. One-dimensional cable

theory is not strictly applicable to this case since the effective length constant during much of the action potential is comparable with the fiber radius. Hence, the waveform of the action potential recorded with a microelectrode at a given point down the length of the axon will be found to be a function of the depth of the electrode within the fiber. We shall return to this question later (Part B).

III. SOLUTIONS OF THREE-DIMENSIONAL ELECTRICAL FIELD PROBLEMS FROM SOLUTIONS OF ANALOGOUS HEAT PROBLEMS

III.1. *General Discussion*

An electrical field problem is one in which the electrical potential varies with position in space. The mathematical statement of the problem necessarily involves a partial differential equation since the quantity of interest, the potential, is a function of more than one dimension and can also be a function of time.

In general, a partial differential equation states the general physical laws relevant to the particular problem; the particular form of the partial differential equation is determined by the coordinates which best take advantage of any symmetry inherent in the particular electrical field of interest. For example, the electric field in a spherical cell is best described by a partial differential equation written in spherical coordinates (radius and angles) whereas a cylindrical cell is described by a system of cylindrical coordinates (a radius, an angle about an axis and a length along the axis). The solution of such a partial differential equation always involves functions appropriate to the geometry. For example, solutions for partial differential equations for spherical coordinates are usually written in terms of "spherical" functions like Legendre polynomials, P_n , and spherical Bessel functions, j_m , and solutions of partial differential equations with cylindrical coordinates are usually written in terms of cylindrical Bessel functions, J_n . There is nothing mysterious about the presence of such higher transcendental functions since just as the sine, cosine, and exponential functions were invented to describe circular problems, so were these other functions invented to describe cylindrical and spherical problems.

One of the essential qualitative features of partial differential equations is that the solution of these equations depends very much on the facts of the particular problem, namely, in the case of electrical field problems, the way field is produced (i.e. its source) and the geometry of the boundary of the field and the laws the field must obey there. The partial differential equation describing an electrical field problem states, in essence, that there is conservation of charge and that charge causes an electric field according to Coulomb's law. These are quite general statements, and must be specialized by the details which define the particular problem, i.e. the boundary conditions. Hence the solution of a partial differential equation depends decisively on the boundary

conditions. Lists of solutions of a given partial differential equation are thus necessarily extensive, covering as they do all sorts of boundary conditions.

An idea of the enormous number of possible solutions of a particular partial differential equation is given in Carslaw and Jaeger's book (Carslaw and Jaeger, 1959) which lists solutions of the partial differential heat equation. In fact, to our knowledge, this is the only equation for which such an extensive listing of analytical solutions has been compiled. It is indeed fortunate that the partial differential equations of the electrical field problems with which we are concerned are special cases of the heat equation. It is understandable, therefore, that we must spend some time describing just how the solutions in Carslaw and Jaeger can be converted into solutions of analogous electrical problems.

However the laws that are relevant to a heat field are basically different from those relevant to an electrical field.† The material in which the heat field exists has both capacity for heat and resistance to the flow of heat within it, whereas the electrical field exists in a space that merely resists the flow of electrical current. From this we should expect that the partial differential equation for heat field problems (equation III.1-1) differs from that for electrical field problems (equation III.1-2).

$$K\nabla^2 P - C\rho \frac{\partial P}{\partial t} = \text{rate of heat applied per unit volume} \quad (\text{III.1-1})$$

$$\frac{1}{R_i} \nabla^2 V = \text{current applied per unit volume} \quad (\text{III.1-2})$$

In equation (III.1-1) P is temperature, K is the heat conductivity ($[\text{cal}][\text{cm}^{-1}][^\circ\text{C}^{-1}][\text{sec}^{-1}]$), ρ is the density of the material ($[\text{g}][\text{cm}^{-3}]$), C is the specific heat ($[\text{cal}][\text{g}^{-1}][^\circ\text{C}^{-1}]$). In equation (III.1-2), V is the electrical potential, R_i is the volume resistivity of the conductor ($[\text{ohms}][\text{cm}]$).

These equations are statements that the formation of a heat field in matter is governed not only by the heat conductance, K , but also by the heat capacity of the matter, ρC , whereas only one electrical property of the matter governs the formation of an electrical field, namely the electrical resistivity R_i . We can make the two equations identical by eliminating the term containing the heat capacitance, C , in equation (III.1-1). This is simply done by setting $\partial P/\partial t = 0$. That is to say, the steady-state solutions of heat problems can be used to solve steady-state electrical problems. With perhaps only one exception (which we will discuss later), we *cannot* obtain solutions to non-steady-state electrical problems by using non-steady-state solutions of the heat equation. However, as we shall see (Part B), we can convert steady state solutions of electrical problems into non-steady-state solutions of electrical problems, and hence the steady-state solution of a heat problem is all that we need.

From equations (III.1-1) and (III.1-2) we can see that the heat analog of electrical potential, V , is temperature, P ; that of current, the flow of heat;

† At times long compared to the relaxation time of the conductor the relaxation time of electrolyte solutions is much less than a microsecond.

and the analog of electrical resistivity of the conductor, R_i , is the reciprocal of heat conductivity, $1/K$. In electrical problems the effects of membrane resistance and capacitance on the formation of the electrical field are described by the equations for the boundary conditions since these membrane elements form a boundary of the field. Hence, the heat analog of membrane resistance in the steady-state electrical problems will be found by comparing the equivalent boundary conditions for the heat and electrical problems.

The boundary conditions appropriate to any of our electrical problems is that the current flowing at right angles to the membrane, in the inner conductor immediately beneath the membrane, is equal to the current leaving through the membrane. Thus the boundary condition is

$$\frac{1}{R_i} \frac{\partial V}{\partial n} + C_m \frac{\partial V}{\partial t} + \frac{1}{R_m} (V - V_0) = 0 \quad (\text{III.1-3})$$

where R_i ([ohm][cm]) is the volume resistivity of the inner conductor, C_m is the specific membrane capacitance ([F][cm⁻²]), R_m is the specific membrane resistance ([ohms][cm²]) and dV/dn is the spatial rate of change (that is, the gradient) of potential in the direction normal to the membrane surface. V is the potential in the inner conductor and V_0 the potential just outside. When $\partial V/\partial t$ is zero, this boundary condition is precisely analogous to the linear heat transfer boundary condition used by Carslaw and Jaeger (which for historical reasons, they call the “radiation” boundary condition).

$$K \frac{\partial P}{\partial n} + H(P - P_0) = 0 \quad (\text{III.1-4})$$

where H is the surface conductivity. We can see from these two equations (III.1-3) and (III.1-4) that the heat analog of membrane conductivity, $1/R_m$ is the surface conductivity, H .

For mathematical convenience we define a constant, Λ , such that $\Lambda = R_m/R_i$. This constant, Λ , has units of [cm] and can be considered as a generalized “space” constant independent of the particular geometry.† The heat equivalent of Λ^{-1} is therefore H/K . In Carslaw and Jaeger H/K is often renamed, h .

There is perhaps one outstanding exception to the rule that only steady-state solutions of electrical problems can be obtained from solutions of heat problems.

This is the non-steady-state solution for a step of voltage applied to one end of a *one-dimensional* cable. The heat problem that has the same equation is the case where a step of temperature is applied at one end of a one-dimensional rod of heat conductor (linear flow of heat assumed) where the conductor is losing heat from its surface. Although the mathematics of the two problems are the same, the physics in the two cases is clearly not the same. The material which has the properties of a capacitor (i.e. stores charge) in the

† Although the term “space” might imply that the constant has units of cm³, we use the word merely to distinguish it from the length constant, λ , of one-dimensional cable theory.

electrical problem (as applied to a nerve fiber) is the cell membrane, whereas in the heat problem it is the conductor itself which has the capacity to store heat.

The identity of the two solutions is fortuitous. It comes about because, in the heat problem, the heat is lost through an infinitely thin surface which, because it has no mass, has therefore no capacity for heat.

Heat entering any element of the conductor is then either stored in its own capacity or it flows out through the "radiation resistance" of the surface. Therefore, in this particular case, heat flows through a resistor (the heat conductivity of the conductor) into a capacitor and a resistance in parallel (heat capacitance of the conductor and the "radiation resistance" of the surface). The mathematical analogy is thus correct in this unusual case, but the physical analogy is incorrect. Although the heat capacity behaves as though it were in parallel with the radiation resistance it is in fact a physical property not of the surface but of the inner conductor, whereas the electrical capacity and resistance are both properties of the surface membrane.

It is this inseparability of heat capacitance from heat conductivity that prevents us from, in general, using the heat capacity of heat problems as an analog of electrical capacity in electrical problems. A finite heat conductance is always associated with a finite mass of material and hence a finite heat capacitance. Furthermore, this capacitance must always be "charged" with heat through the conductance (resistance). We have therefore no isolatable heat analog of electrical capacity. And for the same reason there is no heat analog of an electrical conductance since the latter has no capacity but only resistance. The different location of the heat and electrical capacity is inherent in the equations that describe the respective fields. The heat capacity is only in the partial differential heat field equation whereas the electrical capacity only appears in the boundary conditions to the electrical field equation. Remembering that heat capacity is responsible for the time dependence of the solutions to the heat equation, we now see why transient solutions of heat problems do not correspond in general to transient solutions of electrical problems.

III.2. *Conversion of the Solution of a Heat Problem to the Steady-State Solution of an Electrical Problem*

As we have seen, only steady-state solutions of the heat equation, where the heat capacity plays no role, can be used in solving electrical problems. It is necessary, therefore, to convert the transient solutions of the heat equation given in Carslaw and Jaeger (1959) to steady-state solutions. Many of the solutions in Carslaw and Jaeger give the temperature produced not by a step but by an impulse† of heat. It is necessary to change this solution first into that for a step of heat and then determine the steady state. We shall illustrate

† An impulse of heat can be considered as a pulse of heat of very short duration (as short as we wish) but always of sufficient intensity that the total heat is of unit magnitude. The mathematical statement of such an impulse is the delta "function".

this conversion with an electrical problem involving the three-dimensional spread of current in a leaky electrical cable. In later sections dealing with other geometries we shall simply state the conversion.

The physiological analog of the electrical case is that of a nerve fiber which is idealized as a circular cylinder, the interior of which is filled with a material of uniform resistivity and the exterior of which is assumed to be isopotential. The cylindrical fiber is of radius a ; the electrodes are points and separated by the circumferential angle θ and the axial distance x (Fig. IV. 1-1).

We wish to calculate the steady displacement of membrane potential $V(x, \theta, t)$ at any point caused by a steady current, i_0 , applied by one electrode. This solution can be found from the solution of the corresponding heat conduction problem with the appropriate boundary condition referred to above. This heat problem is that of the distribution of temperature in a cylinder which is losing heat by "radiation" at the surface, heat being steadily applied at a point in the cylinder. The solution of the heat problem with the same geometry for an instantaneous, impulse, source of heat is presented in Carslaw and Jaeger (1959), p. 378, equation 7, and is reproduced in section IV.

The first step in finding the solution to the electrical problem is thus to convert Carslaw and Jaeger's solution (here called $p(x, \theta, t)$) for an impulse source of heat applied at a point to the solution for a step function of heat applied at a point (the latter solution being called $P(x, \theta, t)$). The solution for a steady source of heat is then found by computing the "final" steady-state temperature produced by a step function of heat applied at a point. The solution for a steady source of heat is given by $P(x, \theta) \equiv \lim_{t \rightarrow \infty} P(x, \theta, t)$.

The transient solution to a step function of heat $P(x, \theta, t)$, giving the temperature P as a function of time from the beginning of a step of heat is found using the solution for an impulse of heat, by simulating a step of heat with a continuous series of impulses. The first calculation necessary consists of computing the temperature found at time, t , after an impulse of heat which had occurred previously at time, τ . The second step is to sum the temperatures produced by a continuous sequence of such impulses, the first impulse being at time $\tau = 0$ and the last $\tau = t$. The temperature found at time t , after one impulse of heat had occurred previously at time τ , is $p(x, \theta, t - \tau)$, and the sum (i.e. the integral) of the temperatures contributed by all these impulses gives the temperature $P(x, \theta, t)$ resulting from a step function of heat.

$$P(x, \theta, t) = \int_0^t p(x, \theta, t - \tau)(-d\tau) \quad (\text{III.2-1})$$

The temperature produced by a steady source of heat is then

$$P(x, \theta) = \lim_{t \rightarrow \infty} P(x, \theta, t) = \int_0^{\infty} p(x, \theta, t - \tau)(-d\tau) \quad (\text{III.2-2})$$

IV. THE CYLINDRICAL CELL

In this section the equations describing the spread of potential in a cylindrical nerve or muscle fiber are derived and a practical form of this solution is developed. Computations of the spread of potential for electrodes at different positions are presented in tabular and graphic form. The reader who is primarily interested in the results should go to the sub-section entitled Computations of the Spread of Potential and trust that we have made the derivation and computation correctly.

The equation describing the displacement of membrane potential produced by a step of current injected at a point inside a cylindrical fiber has been stated by Falk and Fatt (1964) in conjunction with their analysis of the input impedance of muscle fibers at high frequencies. This solution will be derived here from the solution of a related problem of heat conduction. The solution is found to be impractical, however, since it involves the roots, which have not been tabulated, of an expression containing Bessel functions (see equation IV. 1-15). Nevertheless, if the length constant, λ , is at least as large as the fiber diameter, these roots will be shown to be closely approximated by the well tabulated roots of the derivatives of Bessel functions. Expressions for the error in this approximation are given. With this approximation the computation of the displacement of the membrane potential as a function of position becomes much easier. This computation shows that the potential at any point can be written as the sum of two terms, the first is the familiar, one-dimensional, cable term and the second describes the steep rise of transmembrane potential around a point source of current. The latter term is quite independent of the particular properties of the fiber membrane, that is to say, it only depends on the size of the fiber and the position of the electrodes. The first term, however, depends on the specific membrane resistance, so the *relative* importance of the second term depends on the membrane properties, and is greatest, as expected, when the length constant is small.

IV.1. *Solution of the Three-dimensional Cable Equation*

Figure IV.1-1 shows the geometry of the system of interest if the nerve is idealized as a circular cylinder, the interior of which is filled with material of

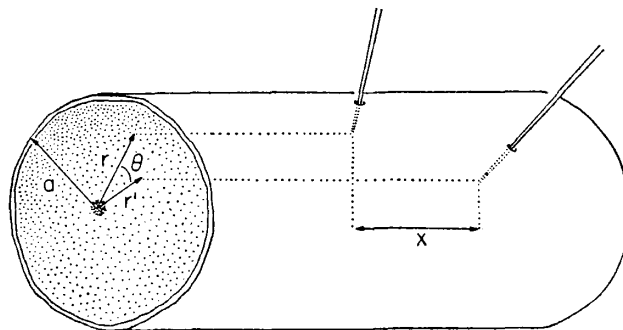

FIG. IV.1-1. The cylindrical cell with microelectrodes.

uniform resistance and the exterior of which is assumed to be isopotential. The cylindrical fiber is of radius a ; the points within the fiber at which the current is injected and the potential recorded are separated by the circumferential angle θ , and the axial distance x . The distance of these points from the axis of the fiber is r' and r . The equations describing the spread of potential in any linear symmetrical system are also symmetrical in r and r' . That is to say, it is irrelevant whether r or r' refers to the position of the point source of current or the position of the point of potential measurement. The volume resistivity of the interior of the fiber is R_i ([ohm][cm]), and hence the resistance (to longitudinal current flow) of a unit length of the interior of the fiber is $r_i = R_i/\pi a^2$ ([ohms][cm⁻¹]). With regard to the resistive properties of the membrane, it would seem natural to describe them in terms of the volume resistivity of the membrane material. However, the effective thickness of the membrane is not known and hence it is both conventional and sensible to describe the resistive properties of the membrane in terms of a specific resistance, namely the resistance (to radial current flow) of 1 cm² of membrane— R_m ([ohms][cm²])—so that the resistance of the membrane of a unit length of fiber is $r_m = R_m/2\pi a$ ([ohms][cm]). The d.c. length constant, λ , [cm] is given by $\frac{1}{2}(r_m r_i)^{\frac{1}{2}}$.

We wish to calculate the displacement of potential $V(x, \theta)$ at any point within the cell caused by a steady current, i_0 , applied at another point within the cell. This solution can be found from the solution to the corresponding heat conduction problem in the way that we described in the previous section.

The temperature produced by a steady source of heat was found to be given by

$$P(x, \theta) = \lim_{t \rightarrow \infty} P(x, \theta, t) = \int_{\tau=0}^{\tau=t=\infty} p(x, \theta, t - \tau)(-d\tau) \quad (\text{IV.1-1})$$

Using the appropriate solution from Carslaw and Jaeger (equation 7, p. 378) for an impulse of heat, we have for $P(x, \theta)$, where $\kappa = K/\rho C$

$$P(x, \theta) = \frac{1}{2\pi a^2} \sum_{n=-\infty}^{n=+\infty} \cos n\theta \sum_{\alpha} \frac{\alpha^2 J_n(\alpha r) J_n(\alpha r')}{\left[\alpha^2 + h^2 - \frac{n^2}{a^2} \right] J_n^2(\alpha a)} \int_0^{\infty} \frac{e^{-\frac{x^2}{4\kappa(\tau-t)} - \kappa\alpha^2(t-\tau)}}{\sqrt{\pi\kappa(t-\tau)}} (-d\tau) \quad (\text{IV.1-2})$$

where $\alpha\alpha$ is each positive number for which the following equation is true.

$$\alpha J_n'(a\alpha) + hJ_n(a\alpha) = 0 \quad (\text{IV.1-3})$$

The above integration can be performed using a table of Laplace transforms to compute definite integrals. This trick is quite useful since extensive tables

of Laplace transforms are available. This is illustrated by first recognizing that equation (IV.1-2) is of the form

$$P(x, \theta) = C(x, \theta, r, r') \int_0^{\infty} f(T) e^{-sT} dT \quad (\text{IV.1-4})$$

where $f(T) = [\pi\kappa T]^{-\frac{1}{2}} \exp[-x^2/4\kappa T]$ (IV.1-5)
 C is a constant, $T = t - \tau$; ($dT = -d\tau$ since t does not vary during this integration) and $s = \kappa\alpha^2$. By definition the integral in equation (IV.1-4) is the Laplace transform of $f(T)$, which for this particular $f(T)$ is listed by Roberts and Kaufmann (1966) as equation 3.2.6. on p. 22 and is reproduced below in a slightly modified form.

$$\int_0^{\infty} t^{-\frac{1}{2}} e^{-\frac{1}{4}(a/t)} e^{-st} dt = \pi^{\frac{1}{2}} s^{-\frac{1}{2}} e^{-\alpha^{\frac{1}{2}} s^{\frac{1}{2}}} \quad (\text{IV.1-6})$$

In terms of heat problem variables, and noting $\alpha = x^2/\kappa$,

$$\frac{1}{\pi^{\frac{1}{2}} \kappa^{\frac{1}{2}}} \int_0^{\infty} T^{-\frac{1}{2}} e^{-x^2/4\kappa T} e^{-\alpha^2 \kappa T} dT = \frac{1}{\pi^{\frac{1}{2}} \kappa^{\frac{1}{2}}} \left[\pi^{\frac{1}{2}} \alpha^{-1} \kappa^{-\frac{1}{2}} e^{-\kappa^{\frac{1}{2}} \alpha x \kappa^{-\frac{1}{2}}} \right] \quad (\text{IV.1-7})$$

$$= \kappa^{-1} \alpha^{-1} e^{-\alpha x} \quad (\text{IV.1-8})$$

Substituting (IV.1-8) in (IV.1-2) we get

$$P(x, \theta) = \frac{1}{2\pi a^2} \sum_{n=-\infty}^{n=\infty} \cos n\theta \sum_{\alpha} \frac{\alpha^2 \kappa^{-1} \alpha^{-1} e^{-\alpha x} J_n(\alpha r) J_n(\alpha r')}{\alpha^2 + h^2 - \frac{n^2}{a^2}} \frac{J_n^2(\alpha a)}{J_n^2(\alpha a)} \quad (\text{IV.1-9})$$

Rearranging,

$$P(x, \theta) = \frac{1}{2\pi \kappa} \sum_{n=-\infty}^{n=+\infty} \cos n\theta \sum_{\alpha} \frac{\alpha e^{-\alpha x}}{\alpha^2 a^2 - n^2 + a^2 h^2} \frac{J_n(\alpha r) J_n(\alpha r')}{J_n^2(\alpha a)} \quad (\text{IV.1-10})$$

Now on exchanging heat variables for the equivalent electrical variables,

$K = R_i^{-1}$, $h = R_i/R_m = a/2\lambda^2$, and letting $\beta = \alpha a$, we get†

$$V(x, \theta) = \frac{i_0 R_i}{2\pi a} \sum_{n=-\infty}^{n=+\infty} \cos n\theta \sum_{\beta} \frac{\beta e^{-\beta x/a}}{\beta^2 - n^2 + \frac{1}{4}(a/\lambda)^4} \frac{J_n(\beta r/a) J_n(\beta r'/a)}{J_n^2(\beta)} \quad (\text{IV.1-11})$$

†The variable i_0 appears in equation (IV.1-11), whereas no equivalent variable appeared in the heat equation since for simplicity we assumed a heat source of unit strength. Furthermore, because of the way Carslaw and Jaeger define their unit source (see p. 256, footnote), the heat solution has been divided by ρC .

Substituting $\pi a^2 r_i$ for R_i ,

$$V(x, \theta) = \frac{i_0 r_i a}{2} \sum_{n=-\infty}^{n=+\infty} \cos n\theta \sum_{\beta} \frac{\beta e^{-\beta x/a}}{\beta^2 - n^2 + \frac{1}{4}(a/\lambda)^4} \frac{J_n(\beta r/a) J_n(\beta r'/a)}{J_n^2(\beta)} \quad (\text{IV.1-12})$$

Similarly in the root equation (IV.1-3) we substitute for the heat variable, h , the electrical equivalent, R_i/R_m , and let $\beta = a\alpha$. Then, equation (IV.1-3), rearranged, becomes

$$\beta \frac{J'_n(\beta)}{J_n(\beta)} = -a \frac{R_i}{R_m} \quad (\text{IV.1-13})$$

but since

$$\lambda = \sqrt{r_m/r_i} = \sqrt{\frac{R_m a}{2R_i}}$$

we see that

$$\frac{R_m}{R_i} = \frac{2\lambda^2}{a} \quad (\text{IV.1-14})$$

Substituting in equation (IV.1-13) we get the root equation

$$\beta \frac{J'_n(\beta)}{J_n(\beta)} = -\frac{1}{2} \left[\frac{a}{\lambda} \right]^2 \quad (\text{IV.1-15})$$

Note equation (IV.1-15) defines β as all those positive numbers for which the equation is true, i.e. the β 's are the roots of the equation.

In these equations J_n is a Bessel function of the first kind, order n (Abramowitz and Stegun, 1967), and the prime denotes differentiation with respect to the entire argument of the Bessel function, here β . For the case where the electrodes are situated just below the membrane, i.e. $r = r' = a$, equation (IV.1-12) simplifies

$$V(x, \theta) = \frac{i_0 r_i a}{2} \sum_{n=-\infty}^{n=+\infty} \cos n\theta \sum_{\beta} \frac{\beta e^{-\beta x/a}}{\beta^2 - n^2 + \frac{1}{4} \left(\frac{a}{\lambda} \right)^4} \quad (\text{IV.1-16})$$

IV.2. Determination of a Convenient Expression for the Roots

The solution, equation (IV.1-12), cannot be used unless the roots of equation (IV.1-15) can be evaluated. Since these roots are inadequately tabulated (Carslaw and Jaeger, 1959, p. 493) they must be evaluated by some numerical method, such as Newton's method or by inverse interpolation from tables (Onoe, 1958, can be used if the roots are real), or approximated by known functions. Furthermore, since the roots depend on the properties of the fiber,

i.e. on a/λ , the numerical process would have to be repeated for each a/λ of interest. We will see that only one root, the "dominant" root (the smallest root for $n = 0$) can be approximated by a simple function. However, it is possible to show for the case where a/λ is smaller than 0.5; the other roots of equation (IV.1-15) become quite independent of a/λ and can be closely approximated by well-tabulated roots, so that it becomes easy to use the solution (IV.1-12) in a variety of cases of interest.

Recently, numerical evaluations of the roots β have been performed (Adrian, Costantin, and Peachey, 1969). We have been able to check our approximations and to correct several errors thanks to the generosity of L. D. Peachey, who has made the results of his computations available to us.

The development of this approximation begins with a consideration of equation (IV.1-15). When a/λ is small, the R.H.S of this equation becomes small and hence the roots, β , of this equation approach those of this equation with the right-hand member zero. That is to say, the roots β , of equation (IV.1-15) when $a/\lambda \rightarrow 0$, approach the roots, z_0 , of the equation $F_n(z) = 0$, where $F_n(z)$ is defined as

$$F_n(z) \equiv z \frac{J'_n(z)}{J_n(z)} \quad (\text{IV.2-1})$$

The roots, z_0 , are defined then by the expression:

$$F_n(z_0) = z_0 \frac{J'_n(z_0)}{J_n(z_0)} = 0 \quad (\text{IV.2-2})$$

Now $F_n(z) = 0$ when either $J'_n(z) = 0$ or $J_n(z) = \infty$. Since $J_n(z)$ is never infinite (for $z > 0$), $F_n(z)$ is 0 only when $J'_n = 0$.[†] That is the roots of the equation $F_n(z) = 0$ are the roots of the equation $J'_n(z) = 0$. These roots z_0 , are of course independent of the particular value of a/λ , for they are the roots of the equation $F_n(z) = 0$, which equation does not include any membrane properties.

In order to examine how well the roots z_0 approximate the roots β used in the solution of equation (IV.1-15), the distinction between these roots must be kept clearly in mind. The roots z_0 are those numbers that satisfy the equation $F_n(z) = 0$ and would be identical to the roots of equation (IV.1-15) were the right-hand member of that equation zero. However, the roots β , are the roots of equation (IV.1-15) in which the right-hand member is not zero, in fact the roots β are the positive numbers which satisfy the equation $F_n(\beta) = -0.5(a/\lambda)^2$. The two sets of roots clearly coincide if $a/\lambda = 0$. Moreover, if the right-hand side of equation (IV.1-15) is sufficiently small, the numbers z_0 become a good approximation to the roots of equation (IV.1-15).[‡]

We must now determine just how small a/λ must be to make this approximation satisfactory. For this purpose, it is convenient to develop an expression which gives the value of $F_n(z)$ when z is close to z_0 ; $F_n(z)$ is therefore

[†] The factor z in the numerator of equation (IV.2-1) has not been ignored; $z = 0$ is also a root of $J'_n(z)$.

[‡] Since $F_n(z)$ is a continuous function for the range of z of interest.

close to zero. This expression can then be substituted into equation (IV.2-1) to show just how much z must be adjusted from z_0 to make $F_n(z) = -0.5(a/\lambda)^2$. If z must be adjusted less than 2% to satisfy this equation (for a certain a/λ), the roots z_0 are considered to be a sufficiently accurate approximation to the root β , for that and smaller values of a/λ .

If the difference between the root z_0 and β is called h (i.e., $h = \beta - z_0$) the required expression is given with sufficient accuracy by the first term of the Taylor expansion of $F_n(z)$ around its root z_0 .

$$F_n(\beta) = F_n(z_0 + h) = F_n(z_0) + hF_n'(z_0) + \dots \quad (\text{IV.2-3})$$

Substitution of the explicit expression for $F_n'(z_0)$ (see section IV.6) into equation (IV.2-3) and then into (IV.1-15) gives an expression for how far β is from z_0

$$\frac{\beta - z_0}{z_0} = \frac{h}{z_0} = \frac{0.5(a/\lambda)^2}{z_0^2 - n^2} \quad (\text{IV.2-4})$$

The fractional difference between the two roots β and z_0 , h/z_0 , depends on the properties of the fiber (i.e. a/λ), the order, n , of the function, and the value of the root z_0 . The fractional error is largest (for given fiber properties) when z_0' is the smallest root of $J_n'(z)$ with $n = 1$, i.e. when $z_0 \doteq 1.841$. This root is named $j'_{1,1}$ in the standard nomenclature for the roots of Bessel functions (Olver, 1960). Under these conditions when the length constant is greater than two fiber diameters ($a/\lambda < 0.25$), the fractional difference between β and z_0 is less than 2%. Even when the length constant equals one diameter ($a/\lambda = 0.5$) the error is less than 6%. Higher order roots (i.e. larger roots) of equation (IV.1-15) are much better approximated by the corresponding roots, z_0 .

The above discussion shows the closeness of the roots β and z_0 for all conditions under which the Taylor expansion (IV.2-3) is valid. However, the expansion fails to approximate the "dominant" root of equation (IV.1-15), namely the smallest root when $n = 0$, since it fails to describe the function $F_n(z)$ if z is very small when $n = 0$. A suitable expansion for $F_0(z)$ in this region can be developed from a similar expression in Onoe (1958) (equation 3.16). For small z

$$F_0(z) = -\frac{z^2}{2} - \frac{z^4}{8} - \dots \quad (\text{IV.2-5})$$

Neglecting all but the first term of equation (IV.2-5) and substituting that term into equation (IV.1-15), gives the expression for the dominant root;

$$\beta = \frac{a}{\lambda} \quad (\text{IV.2-6})$$

This expression is accurate within 2% as long as the length constant, λ , is greater than one fiber diameter.

The dominant root (given by equation IV.2-6) clearly has a different physical significance from the other roots, since it alone depends on the properties of the fiber (to the accuracy implicit in the approximations). Substitution of this root $\beta = a/\lambda$ into the appropriate term ($n = 0$) of the solution (IV.1-12) and neglecting the term $0.25 (a/\lambda)^4$ in the denominator enables the "dominant" term of the solution to be calculated.

$$\frac{1}{2}i_0 r_i \lambda Q e^{-x/\lambda} = \frac{1}{2}i_0 (r_m r_i)^{\frac{1}{2}} Q e^{-x/\lambda} \quad (\text{IV.2-7})$$

The second factor, Q , in this "dominant" term is given by equation (IV.2-8) and approximates unity as we shall see below. Since the dominant root is equal to a/λ ,

$$Q = \frac{J_0(\beta r/a) J_0(\beta r'/a)}{J_0^2(\beta)} = \frac{J_0([a/\lambda][r/a]) J_0([a/\lambda][r'/a])}{J_0^2(a/\lambda)} \quad (\text{IV.2-8})$$

Because $r/a < 1$, $r'/a < 1$ and $a/\lambda < 0.25$, the argument of the Bessel functions is sufficiently small that a Taylor expansion can be used

$$\frac{J_0\left(\frac{a r}{\lambda a}\right) J_0\left(\frac{a r'}{\lambda a}\right)}{J_0^2\left(\frac{a}{\lambda}\right)} \doteq \frac{\left[1 - \frac{1}{4}\left(\frac{a r}{\lambda a}\right)^2\right] \left[1 - \frac{1}{4}\left(\frac{a r'}{\lambda a}\right)^2\right]}{1 - \frac{1}{4}\left(\frac{a}{\lambda}\right)^2} \quad (\text{IV.2-9})$$

This expression is very close to unity for the range of r , r' and λ of interest (within 1%). Thus, the "dominant" term described in equation IV. 2-7 is simply the classical expression which describes the one dimensional spread of current.

The other roots determine the correction of the classical expression necessary to describe the steep rise of potential near a point source of current.

IV.3 Computation of the Spread of Potential

The solution, (equation IV.1-12), can now be rewritten using the approximation of the roots described above

$$V(x, \theta) = 0.5 r_i i_0 a [L(x) + S(x, \theta)] \quad (\text{IV.3-1})$$

where L and S represent the spatial decrement of potential caused, respectively, by one-dimensional and three-dimensional spread of current and are given by

$$L(x) \equiv \frac{\lambda}{a} e^{-x/\lambda} \quad (\text{IV.3-2})$$

$$S(x, \theta) \equiv \sum_{n=-\infty}^{+\infty} \sum_{s=1}^{s=\infty} A_{n,s}^* \cos n\theta \exp \left[-j'_{n,s} \left(\frac{x}{a} \right) \right] \quad (\text{IV.3-3})$$

where

$$A_{n,s}^* = A_{n,s} \frac{J_n\left(j'_{n,s} \cdot \frac{r}{a}\right) \cdot J_n\left(j'_{n,s} \cdot \frac{r'}{a}\right)}{J_n^2(j'_{n,s})} \quad (\text{IV.3-4})$$

where

$$A_{n,s} \equiv \frac{j'_{n,s}}{j_{n,s}^2 - n^2} \quad (\text{IV.3-5})$$

The roots z_0 have been renamed here in order to place them in a systematic array in the conventional manner. The symbol $j'_{n,s}$ represents the s th root (in order of increasing magnitude) of the function $J'_n(z)$. These roots are extensively tabulated in Olver (1960). Some of the roots $j'_{n,s}$ and the coefficients, $A_{n,s}$ are given in Table 1; this table greatly facilitates the calculation of potential as a function of position. In each box in this table there are two numbers, the lower is $j'_{n,s}$ the upper is $A_{n,s}$. The value of n and s for each box is indicated across the top of the table and down the side respectively.

Some discussion of the accuracy of equations (IV.3-1, 2, 3, 4, 5) is necessary. The term $0.25 (a/\lambda)^4$ does not appear in the denominator of equation (IV.3-5) since for $(a/\lambda) < 0.25$ the term is negligible. For finite electrode separation (i.e. $x \neq 0$), the error in the solution caused by the approximate nature of the roots is hardly larger than the largest error in any root, since the sum converges rapidly. Thus this solution is thought to be quite accurate whenever the length constant is greater than two fiber radii, and is considered reasonably accurate when the length constant is greater than one fiber radius.

IV.4. Plots of the Spread of Potential

We will first discuss the case where the tips of the microelectrodes are just beneath the membrane since all of the qualitative effects of the three dimensional spread of current are illustrated by this case. Moreover, at least with larger fibers (frog skeletal muscle and invertebrate nerve), this is the most likely position of the electrode tips since it seems unlikely that the electrode could penetrate more than a small fraction of the fiber radius without causing a large leakage. For this case, equations (IV.3-1, 2, 3, 4, 5) are applicable, the equations being simplified by setting $r = r' = a$.

IV.4a Both electrode tips just beneath the membrane.

Computations of the value of V for various values of x , θ , and λ/a using equations (IV.3-1, 2, 3, 4, 5) have been made. The general reader would be most interested in the size of the correction term for the three-dimensional spread of current, S , relative to the size of the one-dimensional term, L , in equation (IV.3-1). If $\lambda \gg a$ then the correction term, S , will be small relative to that of the one-dimensional term L . However, it must be remembered in

this connection that the effective space constant (see Part B: the a.c. case) varies not only with R_m but with the rate of change of potential as well.

$$\frac{L+S}{L}$$

TABLE 2. FACTOR BY WHICH VOLTAGE PREDICTED BY ONE-DIMENSIONAL THEORY MUST BE MULTIPLIED TO GIVE VOLTAGE PREDICTED BY THREE-DIMENSIONAL THEORY

λ/a	x/a θ°	0.25	0.5	0.75	1	2
2.0	0	2.81	1.78	1.44	1.27	1.06
	5.6	2.67	1.76	1.43	—	—
	11.3	2.36	1.70	1.41	1.26	—
	22.5	1.79	1.53	1.35	1.23	—
	45	1.22	1.22	1.18	1.14	1.04
	90	0.83	0.89	0.94	0.96	1.00
	135	0.70	0.76	0.82	0.87	0.96
	180	0.66	0.73	0.79	0.84	0.95
4.0	0	1.85	1.34	1.18	1.11	1.02
	5.6	1.79	1.33	1.18	—	—
	11.3	1.64	1.31	1.17	1.10	—
	22.5	1.37	1.23	1.14	1.09	—
	45	1.10	1.10	1.07	1.05	1.01
	90	0.92	0.95	0.97	0.99	1.00
	135	0.86	0.90	0.93	0.95	0.99
	180	0.84	0.88	0.91	0.94	0.99
10.0	0	1.33	1.13	1.06	1.04	1.01
	5.6	1.30	1.12	1.06	—	—
	11.3	1.25	1.11	1.06	1.03	—
	22.5	1.14	1.09	1.05	1.03	—
	45	1.04	1.04	1.03	1.02	1.00
	90	0.97	0.98	0.99	1.00	1.00
	135	0.95	0.96	0.97	0.98	1.00
	180	0.94	0.96	0.97	0.98	1.00

Voltage predicted by one-dimensional theory, $V^*(x)$, is given by:

$$V^*(x) = \frac{i_0}{2} \sqrt{r_m r_i} e^{-x/\lambda}$$

Voltage predicted by three-dimensional theory, $V(x, \theta)$, both electrodes just beneath the membrane, is given by:

$$V(x, \theta) = \text{factor listed} \times V^*(x)$$

Table 2 lists numbers for certain values of x , θ , and λ/a which are correction factors by which the potential calculated from one-dimensional cable theory must be multiplied to give the potential calculated from three-dimensional cable theory. It will be seen that correction factors for short length constants (e.g. $\lambda/a = 2.0$) are enormous, especially with small electrode separation and

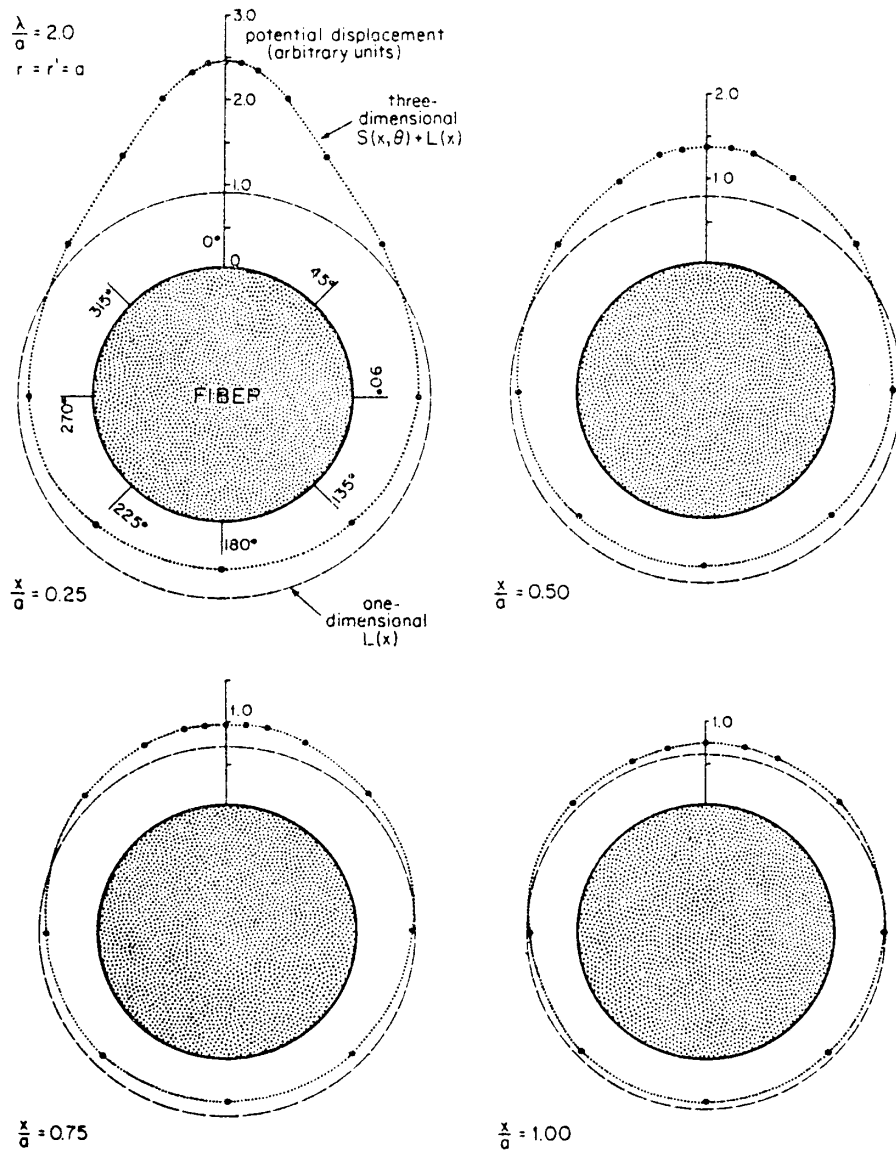

FIG. IV.4-1. Plots of the circumferential displacement of transmembrane potential at various distances, x/a , along the longitudinal axis away from the current electrode. In each drawing in this figure, the inner circle represents the fiber in cross-section at a given distance, x/a , indicated in each drawing. The radial distance from the circumference of the inner circle to the dashed circle represents the displacement in transmembrane potential calculated from one-dimensional cable theory. The radial distance from a point on the circumference of the inner circle to the outer dotted curve represents the displacement in the true transmembrane potential as calculated from three-dimensional cable theory. Both electrodes just beneath the surface, $r = r' = a$; $\lambda/a = 2.0$.

are by no means insignificant even when $\lambda/a = 10$ if the electrode separation is small. Some of the data from Table 2 is used in Fig. IV.4-1. In each drawing in this figure, the inner circle represents the fiber in cross-section at a given distance (indicated in each drawing) away from the point of injection of current. The radial distance from the circumference of the inner circle to the outer dashed circle represents the membrane potential as calculated from one-dimensional cable theory. The radial distance from the inner circle to the outer dotted line represents the transmembrane potential as calculated from three-dimensional theory. Only the points indicated on this line are calculated values of membrane potential; the continuous line between the points was drawn free hand.

The following discussion considers the three-dimensional term S , of equation (IV.3-1), in more detail. Figure IV.4-2 shows how the three-dimensional term S , varies with x/a , for different angular separation, θ , of the electrodes. In other words this figure shows how the magnitude of the three-dimensional term varies along the length of the cable. The three-dimensional

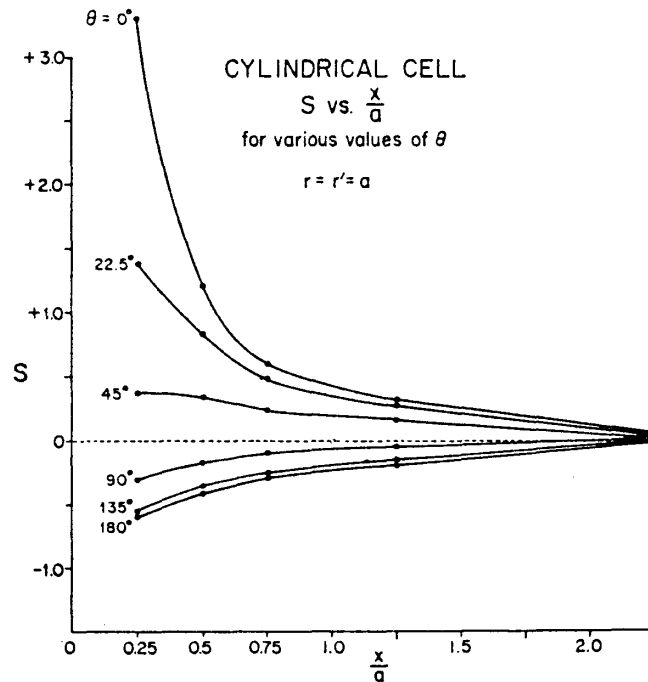

FIG. IV.4-2. The value of the three dimensional correction term, $S(x, \theta)$, in equation (IV.3-1) plotted as a function of distance, x/a . Each of the six curves is for a different angular separation (indicated on the curve), θ , of the tips of the two electrodes both just beneath the membrane.

term gets very large and depends steeply on x for $\theta = 0$. For greater angular separations, the effect is both smaller and less variable. Figure IV.4-3 shows the same data but in a different form. Here the magnitude of the three-dimensional term is plotted as a function of angular separation θ , at different

positions along the fiber. It is of interest to note that for an angular separation of about 70° , the three-dimensional term is very small for all electrode separations considered here.

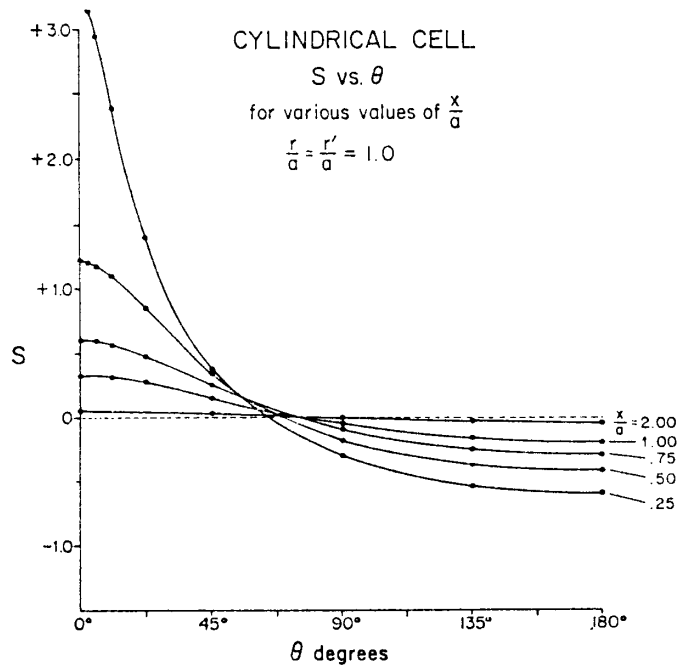

FIG. IV.4-3. The value of the three-dimensional correction term, $S(x, \theta)$ in equation (IV.3-1) plotted as a function of the angular separation, θ , of the tips of the two electrodes. Each curve is for a particular value (indicated on the curve), of x/a . Both electrodes just beneath the surface, $r = r' = a$.

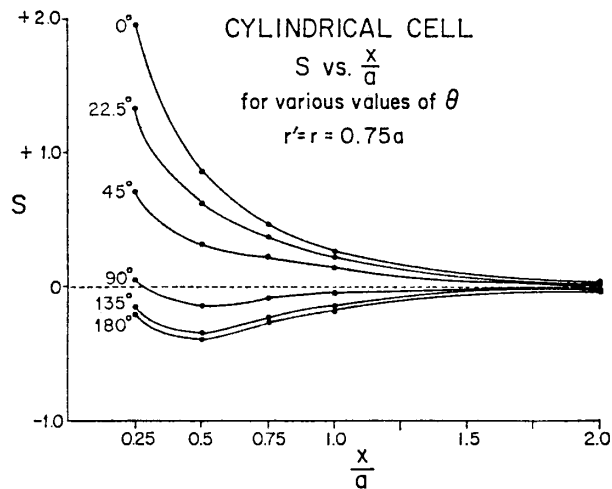

FIG. IV.4-4. The value of the three-dimensional correction term, $S(x, \theta)$, in equation (IV.3-1) plotted as a function of distance, x/a . Each of the six curves is for a different angular separation (indicated on the curve), θ , of the tips of the two electrodes. Both electrodes deep ($r = r' = 0.75a$).

IV.4b. *Both electrodes deep in the cell (i.e. $r = r' = 0.75a$).*

This case is perhaps more applicable to fibers of small radius, but would apply to big fibers if the electrodes are inserted deep into the cell. Figures IV.4-4 and 5 show the same qualitative behaviour as seen in Fig. IV.4-2 and IV.4-3 where the electrodes are just beneath the surface, except that in the plot of S vs. x/a in Fig. IV.4-4 there is a maximum in the magnitude of S for large angles.

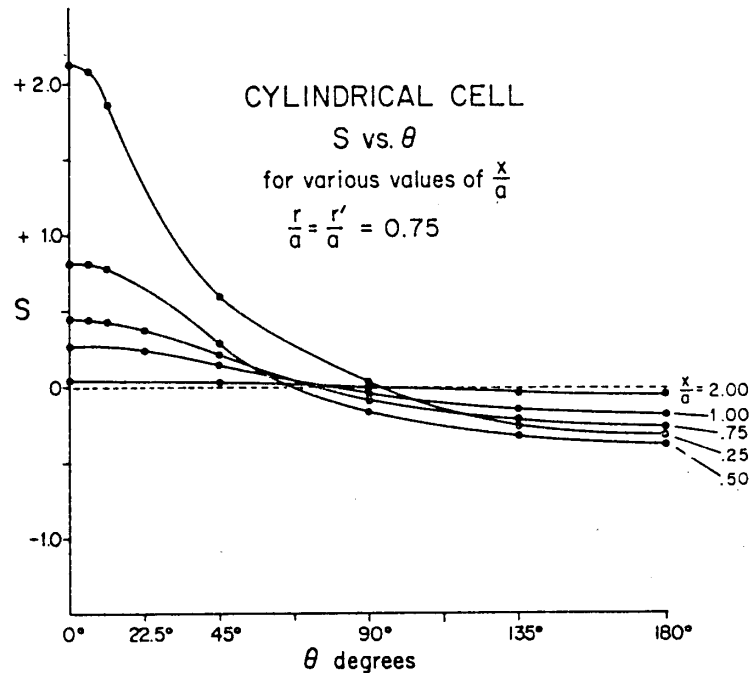

FIG. IV.4-5. The value of the three-dimensional correction term, $S(x, \theta)$, in equation (IV.3-1) plotted as a function of the angular separation, θ , of the tips of the two electrodes. Each curve is for a particular value (indicated on the curve), of x/a . Both electrodes deep ($r = r' = 0.75a$).

IV.4c. *One electrode just beneath the surface and the other deep.*

These calculations are relevant to the questions, what is the transmembrane potential when the current electrode is deep and the converse, what is the potential deep in the fiber when the current is injected just beneath the membrane. Remember that r' can be the position of the voltage or current electrode, conversely for r . Figures IV.4-6 and IV.4-7 give plots of S as a function of x/a and as a function of θ , respectively, for the case of one electrode just beneath the surface and the other electrode positioned at a depth $0.5a$ in the fiber. Figures IV.4-8 and IV.4-9 give similar plots for one of the electrodes at a depth of $0.75a$ in the fiber.

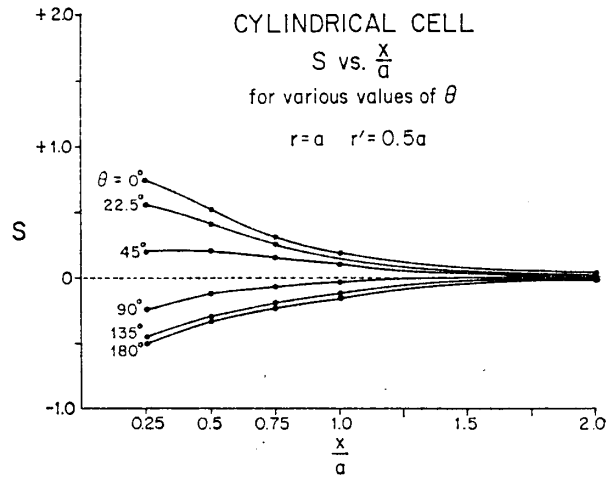

FIG. IV.4-6. The value of the three-dimensional correction term, $S(x, \theta)$, in equation (IV.3-1) plotted as a function of distance, x/a . Each of the six curves is for a different angular separation (indicated on the curve), θ , of the tips of the two electrodes. One electrode deep ($r = a, r' = 0.5a$).

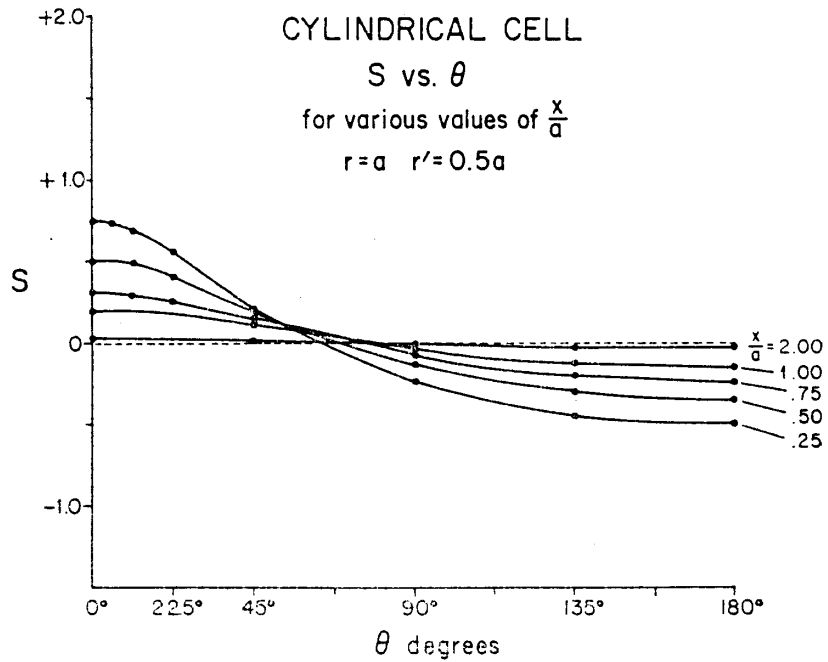

FIG. IV.4-7. The value of the three-dimensional correction term, $S(x, \theta)$, in equation (IV.3-1) plotted as a function of the angular separation, θ , of the tips of the two electrodes. Each curve is for a particular value (indicated on the curve), of x/a . One electrode deep ($r = a, r' = 0.5a$).

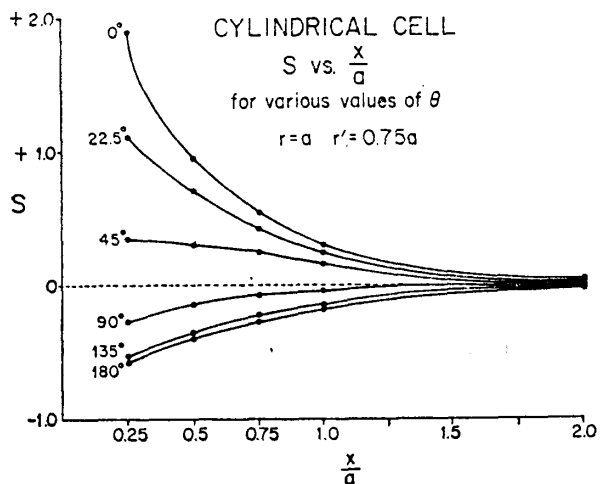

FIG. IV.4-8. The value of the three-dimensional correction term, $S(x, \theta)$, in equation (IV.3-1) plotted as a function of distance, x/a . Each of the six curves is for a different separation (indicated on the curve), θ , of the tips of the two electrodes. One electrode deep ($r = a$, $r' = 0.75a$).

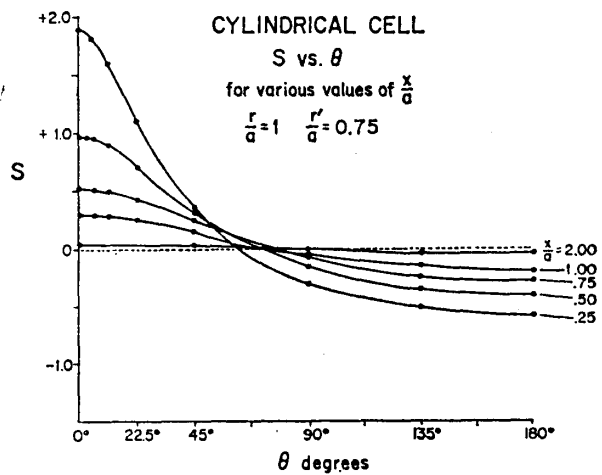

FIG. IV.4-9. The value of the three-dimensional correction term, $S(x, \theta)$, in equation (IV.3-1) plotted as a function of the angular separation, θ , of the tips of the two electrodes. Each curve is for a particular value, (indicated on the curve), of x/a . One electrode deep ($r = a$, $r' = 0.75a$).

IV.5. Universal Figure and Table

Figure IV.5-1 shows a graphical representation of the values of the one-dimensional term, L , and the three-dimensional term, S , of equation (IV.3-1) for the electrodes just beneath the membrane. Table 3 lists the various values of the three-dimensional term S for various values of x , θ , r and r' .

TABLE 3. VALUES OF S : THE THREE-DIMENSIONAL CORRECTION TERM

r	r'	x/a	0.25	0.5	0.75	1	2
		θ°					
a	a	0	3.202	1.212	0.598	0.327	0.042
		2.81	3.136	1.204	—	—	—
		5.63	2.954	1.179	0.589	—	—
		11.25	2.395	1.092	0.563	0.315	—
		22.5	1.396	0.827	0.475	0.278	—
		45	0.381	0.337	0.245	0.165	0.027
		90	-0.304	-0.169	-0.089	-0.045	-0.003
		135	-0.536	-0.367	-0.246	-0.161	-0.027
		180	-0.596	-0.422	-0.292	-0.197	-0.036
		a	$0.75a$	0	1.89	0.97	0.52
2.81	1.87			0.96	—	—	—
5.63	1.81			0.95	0.51	0.29	—
11.25	1.60			0.89	0.49	0.28	—
22.5	1.11			0.71	0.42	0.25	—
45	0.37			0.32	0.23	0.15	0.03
90	-0.031			-0.16	-0.08	-0.04	-0.00
135	-0.50			-0.35	-0.24	-0.15	-0.03
180	-0.59			-0.41	-0.28	-0.19	-0.03
$0.75a$	$0.75a$			0	1.92	0.85	0.45
		2.81	1.89	—	—	—	—
		5.63	1.83	0.83	0.45	—	—
		11.25	1.61	0.79	0.43	—	—
		22.5	1.07	0.64	0.38	0.22	—
		45	0.35	0.30	0.21	0.14	0.02
		90	-0.23	-0.15	-0.08	-0.04	-0.00
		135	-0.49	-0.33	-0.21	-0.14	-0.02
		180	-0.55	-0.37	-0.26	-0.17	-0.03
		a	$0.5a$	0	0.75	0.52	0.31
5.63	0.73			—	—	—	—
11.25	0.70			0.48	0.30	—	—
22.5	0.56			0.42	0.26	—	—
45	0.20			0.22	0.15	0.11	0.02
90	-0.24			-0.07	-0.07	-0.03	-0.00
135	-0.45			-0.29	-0.20	-0.12	-0.02
180	-0.50			-0.34	-0.24	-0.15	-0.03

IV.6. Appendix: Approximation to the Roots β

$$F_n(\beta) = F_n(z_0 + h) = F_n(z_0) + hF'_n(z_0) + \dots \quad (\text{IV.6-1})$$

where $F_n(z_0) = 0$

$$F_n(z) \equiv z \frac{J'_n}{J_n} \quad (\text{IV.6-2})$$

$$F'_n(z) = \frac{J'_n}{J_n} + z \frac{[J_n J''_n - J_n'^2]}{J_n^2} \quad (\text{IV.6-3})$$

$$F'_n(z) = \frac{F_n(z)}{z} + z \frac{J''_n}{J_n} - \frac{1}{z} F_n^2(z) \quad (\text{IV.6-4})$$

In order to use this expression we must find an explicit expression for J''_n . This could be found by tedious but straightforward application of recurrence relations. However, there is an easier way.

From the differential equation that defines Bessel functions

$$J''_n = -\frac{1}{z} J'_n - \frac{1}{z^2} (z^2 - n^2) J_n \quad (\text{IV.6-5})$$

Substituting this expression for J''_n into equation (IV.6-4) and simplifying we get

$$F'_n(z) = \frac{-F_n^2(z)}{z} - \frac{(z^2 - n^2)}{z} \quad (\text{IV.6-6})$$

$$F'_n(z_0) = -\frac{z_0^2 - n^2}{z_0} \quad (\text{IV.6-7})$$

Substituting this expression for $F'_n(z_0)$ into equation (IV.6-1)

$$F_n(\beta) = F_n(z_0 + h) \doteq -\frac{h(z_0^2 - n^2)}{z_0} \quad (\text{IV.6-8})$$

$$\text{but } F_n(\beta) = -0.5(a/\lambda)^2 \quad (\text{IV.6-9})$$

$$\text{so that } h = \frac{0.5(a/\lambda)^2 z_0}{z_0^2 - n^2} \quad (\text{IV.6-10})$$

and the fractional difference between the value of β and z_0 is given by

$$\frac{\beta - z_0}{z_0} = \frac{h}{z_0} = \frac{0.5(a/\lambda)^2}{z_0^2 - n^2} \quad (\text{IV.6-11})$$

V. THE SPHERICAL CELL

V.1. *Solution of the Spherical Problem*

Another geometry of interest to the physiologist is the spherical cell since this geometry crudely approximates the shape of many cells. The current source that we shall consider is, again, a point source, which is of interest not only because a microelectrode is often used to inject current into such cells, but also, because a single synaptic bouton or small cluster of boutons might well be approximated by a small source of current. Figure V.1-1 shows

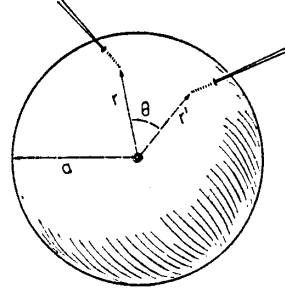

FIG. V.1-1. The spherical cell with microelectrodes.

the geometry of interest: r [cm] is the distance from the center of the sphere to the point at which potential is measured (the radial coordinate of that point); r' [cm] is the radial coordinate of the point at which current is injected; θ [degrees] is the angle between the current source and the point at which potential is measured (i.e. θ is the angular coordinate); a [cm] is the radius of the cell; R_i ([ohm][cm]) is the volume resistivity of the material inside the cell; R_m ([ohm][cm²]) is the specific membrane resistance.

The equation describing the spread of potential within the cell can be found in a manner precisely analogous to that used in solving the cylindrical problem. The solution of the corresponding transient heat problem is found in Carslaw and Jaeger. This solution is first converted into the solution of a steady-state heat problem and then into the solution of the analogous steady-state electrical problem. The solution to the heat problem is given in Carslaw and Jaeger (p. 382, equation 11). The steady-state solution to the electrical problem is†

$$V = \frac{i_0 R_i}{2\pi a} \sum_{m=0}^{m=\infty} (2m + 1) P_m(\cos \theta) \sum_{\beta} \frac{j_m(\beta r/a) j_m(\beta r'/a)}{j_m^2(\beta)} \frac{1}{\beta^2 - m^2 - m + (a/\Lambda^2) - a/\Lambda} \quad (\text{V.1-1})$$

where $P_m(\cos \theta)$ is a Legendre polynomial of degree m (Abramowitz and Stegun, 1967) of argument $\cos \theta$; and j_m is a spherical Bessel function of the

† We have written this solution in terms of spherical Bessel functions, j_m , whereas Carslaw and Jaeger's solution is written in terms of cylindrical Bessel functions. The notation that we have used is in accordance with the modern convention given in Abramowitz and Stegun. These functions j_m and their derivatives j'_m should not be confused with the roots $j'_{n,s}$ of cylindrical Bessel functions.

first kind, of order m , and β are the roots of the following equation

$$\beta \frac{j'_m(\beta)}{j_m(\beta)} = -\frac{a}{\Lambda} \quad (\text{V.1-2})$$

where Λ is the generalized space constant R_m/R_i , given by the ratio of specific membrane resistance to the volume resistivity of the core.

An analysis of these roots along precisely the same lines as in the cylindrical case shows that all but one of the roots are well approximated by the roots of the equation $j'_m(z) = 0$, these latter roots being well tabulated (they are called $a'_{m,s}$ in Olver (1960)). The order of the spherical Bessel function is m , and s is the number of the root, in order of increasing size. The one root not well approximated is the dominant root, i.e. the smallest root when $m = 0$. This latter root is given by $(3a/\Lambda)^{\frac{1}{3}}$ and has special significance as we shall see. The development of these approximations and an analysis of the error involved can be found in section V.2.

Substitution of these expressions for the roots shows that the solution of the three-dimensional problem for a spherical cell has two terms, one that depends on membrane properties (i.e. one which would be correct if there were no potential drops in the conducting core) and one that describes the potential drops in the core and which does not depend on the membrane properties.

$$V = \frac{i_0 R_m}{4\pi a_2} + \frac{i_0 R_i}{2\pi a} \sum_{m=0}^{m=\infty} (2m+1) P_m(\cos \theta) \sum_{s=1}^{s=\infty} \frac{j_m(a'_{m,s} r/a) j_m(a'_{m,s} r'/a)}{j_m^2(a'_{m,s}) [a_{m,s}^2 - m^2 - m]} \quad (\text{V.1-3})$$

This solution is unfortunately not as useful as the corresponding solution for the cylindrical fiber. The double infinite series converges very slowly and, for instance, our computation for $r = r' = 0.8a$ did not converge adequately even after 800 terms. Because of this slow convergence we cannot compute the universal curves as we did in the case of the cylinder and secondly, we cannot be certain of the accuracy of the approximation used in equation (V.1-3). Since the error in each term of equation (V.1-3) is small for a/Λ less than $\frac{1}{4}$ (see section V.2) and since this error decreases markedly with increasing m and/or s it seems safe to conclude that the error in the overall equation is reasonable. This conclusion is of considerable qualitative importance since it enables one to determine that the qualitative effects of the three-dimensional spread of current are similar both in the sphere and the cylinder.

Recently it has been possible to put equation V. 1-3 into much more simple form and thus determine numerical values (personal communication, E. Engel and R. S. Eisenberg).

V.2. Approximations Used in the Spherical Problem

The approximations used in the spherical problem are precisely analogous to those used in the cylindrical problem and fall into two classes: approximations to the roots, β , and approximations in the infinite series.

V.2a. *Approximations to the roots.*

A function, F_m is defined,

$$F_m(x) \equiv x \frac{j'_m(x)}{j_m(x)}; F_m(\beta) \equiv \beta \frac{j'_m(\beta)}{j_m(\beta)} = -\frac{a}{\Lambda} \quad (\text{V.2-1})$$

the roots of which are the well tabulated roots $a'_{m,s}$ of the derivative of the spherical Bessel function j'_m . In other words, when $x = a'_{m,s}$, $F_m(x) = 0$. Since we wish to find how far x must be moved from $a'_{m,s}$ in order to make $F_m = -a/\Lambda$, we expand F_m in a Taylor series about its roots (called x_0 for convenience). The missing mathematical steps in the derivation of equation (V.2-3) are similar to those described for the cylindrical cell.

$$F_m(\beta) \equiv F_m(x_0 + h) = hF'_m(x_0) + \frac{h^2}{2}F''_m(x_0) + \dots \quad (\text{V.2-2})$$

Since the second term is not important for $a/\Lambda < 0.25$,

$$F_m(x_0) \doteq h \frac{[m(m+1) - x_0^2]}{x_0} \quad (\text{V.2-3})$$

Substitution of this last expression into equation (V.2-1) enables one to determine the error in the approximation that the roots are identical with the roots $a'_{m,s}$. When $a/\Lambda = 0.25$ this error is less than 5% for the worst case.

The above discussion fails to approximate the "dominant" root, i.e. the smallest root of equation (V.2-1). This root, β^* , can be determined by writing the explicit expression (Olver, 1960) for $j_0(x)$ and $j'_0(x)$ into the equation defining the roots

$$x \frac{j'_0(x)}{j_0(x)} \equiv x \cot x - 1 = \frac{-a}{\Lambda} \quad (\text{V.2-4})$$

The dominant root can then be found to be given by $\sqrt{3a/\Lambda}$. This latter expression is about 6% too big if $a/\Lambda = 0.25$.

V.2b. *Approximations in the infinite series.*

First, we will substitute the expression for the dominant root, β^* into the equation (V.1-1). The resulting "dominant" term is developed by approximating the factor containing the ratio of spherical Bessel functions, which appears in equation (V.1-1), using the first terms of the appropriate Taylor expansions.

$$\frac{j_0(\beta^*r/a) \cdot j_0(\beta^*r'/a)}{j_0^2(\beta^*)} \doteq \frac{\left(1 - \frac{\beta^{*2}r^2}{6a^2}\right)\left(1 - \frac{\beta^{*2}r'^2}{6a^2}\right)}{1 - \frac{\beta^{*2}}{6}} \quad (\text{V.2-5})$$

If the above approximation, as well as the approximation to the roots is substituted into the infinite series, the resulting term is

$$\frac{R_m}{4\pi a^2} \left[1 + \frac{a}{\Lambda} \left(1 - \frac{r^2 + r'^2}{2a^2} \right) \right] \quad (\text{V.2-6})$$

The error in the above expression is about 3% for $r = r' = a/2$, $a/\Lambda = 0.25$. In many cases the correction term is negligible, and the leading term of the infinite series takes on the simple form $R_m/4\pi a^2$. For $a/\Lambda < 0.25$ all the other terms involving a/Λ in the infinite series are negligible, the worst error in a single term being less than 9%. The full solution then takes the form of equation (V.1-3). This approximate solution shows the same qualitative features as that for the cylinder. It divides into two terms, the conventional term (here what one would find if the interior of the sphere were isopotential) and a correction term, essentially independent of membrane properties. Thus qualitative discussion of these two cases is similar.

VI. THE THIN PLANE CELL

VI.1. *Solution of the Thin Plane Cell*

The solution for the potential anywhere in a two sided slab, can be found by methods precisely analogous to those used for the cylinder and the sphere. The analogous heat solution is found again in Carslaw and Jaeger, p. 373, equation (17). The corresponding solution to the steady state electrical problem is

$$V(R,z) = \frac{R_i}{2\pi L} \sum_{n=1}^{\infty} \frac{\beta'^2 K_0(2\beta'R/L) \cdot f(z,z')}{\beta'^2 + 0.5(L/\Lambda) + 0.25(L/\Lambda)^2} \quad (\text{VI.1-1})$$

where β'_n are all the roots of both expressions:

$$\beta' \tan \beta' = L/2\Lambda \quad (\text{VI.1-2})$$

$$\beta' \cot \beta' = -L/2\Lambda \quad (\text{VI.1-3})$$

and

$$f(z,z') = \left[\cos \frac{2z\beta'}{L} + \frac{L \sin(2z\beta'/L)}{2\Lambda\beta'} \right] \left[\cos \frac{2z'\beta'}{L} + \frac{L \sin(2z'\beta'/L)}{2\Lambda\beta'} \right] \quad (\text{VI.1-4})$$

This solution has been written in terms of the roots β' , whereas the roots α'_n are used in Carslaw and Jaeger. The relation between the roots is $\beta' = \alpha'_n L/2$. Furthermore, the equation defining the roots has been rewritten using the techniques suggested by Carslaw and Jaeger on p. 120.

The coordinates used here are shown in Fig. VI.1-1. The membranes

bounding the solid are at $z = 0$ and $z = L$, the source of current is at depth z' and radial position zero. The point at which potential is measured is at depth z and radial position R . K_0 is a modified Bessel function of the second kind (Abramowitz and Stegun, 1967) and R_i is, as usual, the volume resistivity ([ohm][cm]) of the core material. Λ is the generalized space constant, given by R_m/R_i where R_m is the specific membrane resistance ([ohm][cm²]).

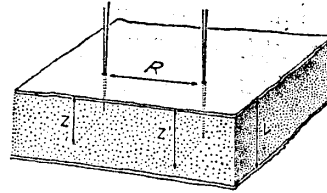

FIG. VI.1-1. The thin plane cell with microelectrodes.

Equation (VI.1-1) is of practical use as it stands since the roots of equations (VI.1-2) and (VI.1-3) are well tabulated (Carslaw and Jaeger, 1959; Abramowitz and Stegun, 1967). However, it is worthwhile searching for approximations to these roots, since only so can we determine whether the solution separates into two components; a radial term and a three-dimensional correction term. Again, the smallest root will produce the largest term in the infiniteseries and so is called the dominant root. Since only equation (VI.1-2) can have a root close to zero, an expression approximating this dominant root can be found by expanding equation (VI.1-2) in a Taylor series for small x , neglecting all but the first term. The resulting expression for the dominant root is

$$\beta' = \sqrt{\frac{L}{2\Lambda}} \quad (\text{VI.1-5})$$

Direct comparison with tables shows that the error in this expression is less than 4% for $L/\Lambda = 0.4$, and less than 2% for $L/\Lambda = 0.2$. The remaining roots, for sufficiently small L/Λ , are given by $\pi, 2\pi, 3\pi, \dots$ for equation (VI.1-2) and for equation (VI.1-3) are given by $\pi/2, 3\pi/2, \dots$. Thus, all the roots are given by $\pi/2, \pi, 3\pi/2, \dots$; i.e. $n\pi/2$ (where $n = 1, 2, 3, \dots$) provided that L/Λ is sufficiently small. Direct comparison with the tables shows that the error in the above approximation is less than 8% for L/Λ less than 0.4 and less than 4% for L/Λ less than 0.2.

The next step in our development of this solution is the substitution of the expressions for the roots into the solution (VI.1-1). Substitution of the dominant root gives the dominant term

$$\frac{R_i}{2\pi L} K_0\left(\frac{R}{L}\sqrt{\frac{2L}{\Lambda}}\right) \quad (\text{VI.1-6})$$

where neglect of the second term in the denominator causes an error 5% or less for L/Λ less than 0.2. The other terms of the expression (VI.1-4) simplify if L/Λ is sufficiently small so that the total expression for the potential is

$$V = \frac{i_0 R_i}{2\pi L} \left[K_0 \left(\frac{R}{L} \sqrt{\frac{2L}{\Lambda}} \right) + 2 \sum_{n=1}^{\infty} K_0(n\pi R/L) f(z, z') \right] \quad (\text{VI.1-7})$$

or

$$V = \frac{i_0 R_i}{2\pi L} [P + Q] \quad (\text{VI.1-8})$$

The error caused by the neglect of the extra terms in the denominator of the infinite series in equation (VI.1-1) is less than 4% for L/Λ less than 0.2. It should be pointed out here that the function $f(z, z')$ defined above (equation VI.1-4) has the value unity if both electrodes are just under the surface membrane.

It is interesting to note that once again our solution consists of two terms, a term depending on the membrane properties and a term independent of the membrane properties. From the analysis of the other geometries we would expect that the first term of the solution would be identical to the solution of a simplified problem, that is to say, when current is assumed to flow in a radial direction parallel to the surface of the plane cell. Woodbury and Crill (1961) and Noble (1962) have obtained such a solution but it differs from the first term in equation (VI.1-7) by a factor of the $\sqrt{2}$ in the argument of the Bessel functions.† The cause of this discrepancy is somewhat obscure but perhaps Woodbury and Crill and Noble failed to consider the presence of two membranes across which current might flow out of the solid.

TABLE 4. THIN PLANE CELL

Tables of values of correction term, Q , of equation (VI.1-7) for various values of R/L .

R/L	0.1	0.15	0.2	0.25	0.3	0.4	0.5	0.75	1.00
Q	6.84	3.92	2.52	1.78	1.32	0.72	0.46	0.07	0.03

Figure VI.1-2 gives the plot of the displacement in transmembrane potential as a function of the radial distance from the current electrode (both electrode tips just beneath one membrane). In Fig. VI.1-3 the second term, the correction term, Q , of equation (VI.1-8) is plotted as a function of R/L .

† The reader should be aware that both Woodbury and Crill and Noble use a different set of units from those used here. While our R_m ([ohm][cm²]) and L [cm] correspond directly with their R_m ([ohm][cm²]) and δ [cm] respectively, our R_i ([ohm][cm]) corresponds to Woodbury's, ρ_i , ([ohm][cm]) and not his r_i ([ohms]). It seems likely that Noble's R_i (units, unspecified) corresponds directly to Woodbury's r_i since such a correspondence would mean that the differential equations that they consider are identical and that the length constants they define are also identical. The length constant " λ " defined by Woodbury and Crill and Noble is given by

$$" \lambda " = \sqrt{\frac{R_m L}{R_i}}$$

(our definition of R_m , R_i , L , but *not* our definition of λ)

The relationship between their length constant " λ " and our generalized space constant Λ is

$$" \lambda " = \sqrt{L\Lambda}$$

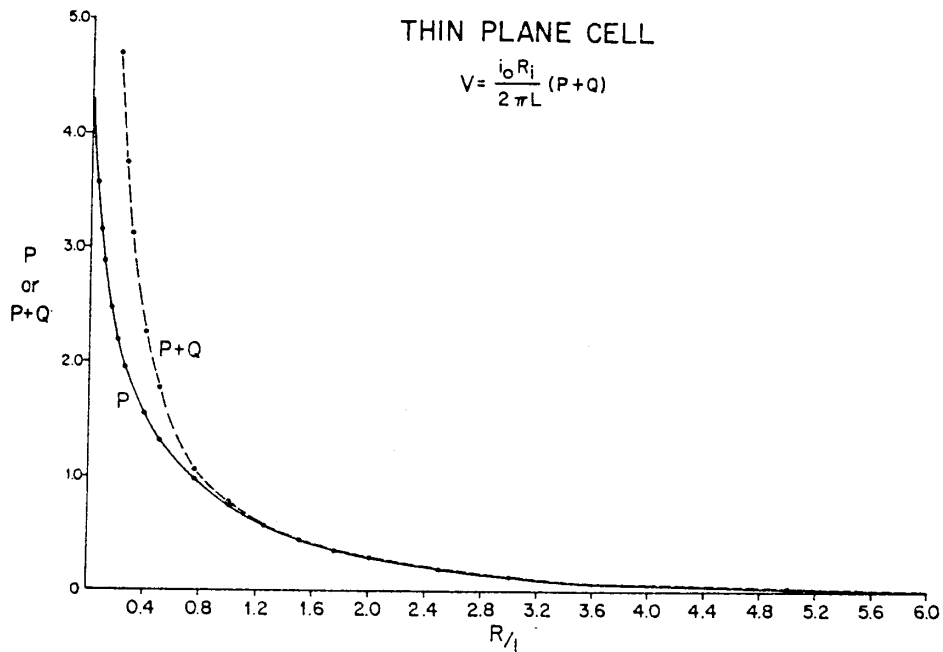

FIG. VI.1-2. The thin plane cell. Plot of the displacement in transmembrane potential as calculated from two-dimensional and three-dimensional theory (proportional to P and $(P + Q)$ respectively) as a function of distance, R/L from a point source of current. Both electrodes just beneath the surface of one membrane. $L/\Lambda = 0.2$

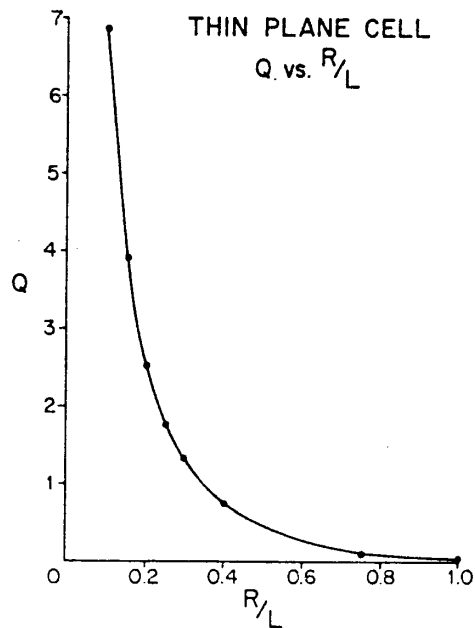

FIG. VI.1-3. The thin plane cell. Plot of the three-dimensional correction term, Q , of equation (VI.1-7, 8) as a function of distance R/L , from the point source of current.

VII. THE THICK PLANE CELL

Although the solution presented above for the sheet is applicable to sheets of arbitrary thickness, the roots are difficult to approximate when the cell is thick and the physical interpretation of the solution becomes obscure. The solution for the thick solid can be found in the usual manner from Carslaw and Jaeger (1959) p. 371, equation (4), although in this case the necessary integration is rather awkward. The solution is also presented directly in Gray, Mathews and MacRobert (1922) p. 150, equation (38) for the case

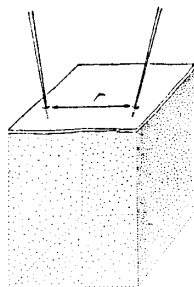

FIG. VII.1-1. The thick plane cell with microelectrodes.

where both electrodes are just under the membrane at separation r . Their solution† can be rewritten in terms of our usual variables as

$$V = \frac{i_0 R_i}{2\pi} \left\{ \frac{1}{r} - \frac{1}{\Lambda} \int_0^{\infty} \frac{e^{-T} dT}{\sqrt{T^2 + r^2/\Lambda^2}} \right\} \quad (\text{VII.1-1})$$

and can be transformed into a tabulated form if the integral is recognized as the Laplace transform of $(a^2 + T^2)^{-\frac{1}{2}}$ (Roberts and Kaufman, 1966, number 13, p. 13) with $s = 1$. Then, the solution can be written as

$$V = \frac{i_0 R_i}{4\Lambda} \left[\frac{2\Lambda}{\pi r} - \{ \mathbf{H}_0(r/\Lambda) - Y_0(r/\Lambda) \} \right] \quad (\text{VII.1-2})$$

where \mathbf{H}_0 is a Struve function‡ (Abramowitz and Stegun, 1967) of order zero and Y_0 is a Bessel function of the second kind also of order zero. A universal plot of this solution is given in Fig. VII. 1-2. It is interesting to note that this solution does not break into two terms, one term that depends on membrane properties and another that depends only on position. This separation does not occur because the symmetry implicit in this problem is very different

†Which fortunately agrees with that derived from Carslaw and Jaeger.

‡The reader should be warned that the symbol H_0 is also used to represent a Hankel function. The Struve function is recognizable since the symbol used is in bold face type.

from that of the other problems. In this case, since the slab is of infinite thickness, the lines of current flow never approach a symmetrical form as they did in the other geometries we have considered.

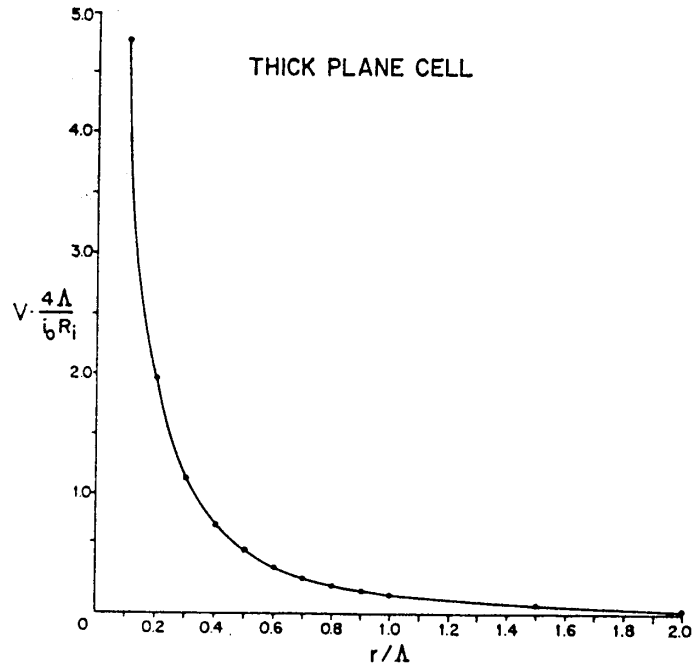

FIG. VII.1-2. The thick plane cell.
Plot of

$$\frac{2\Lambda}{\pi r} - \left\{ H_0(r/\Lambda) - Y_0(r/\Lambda) \right\}$$

as a function of r/Λ . If the ordinate values are multiplied by $\frac{i_0 R_i}{4\Lambda}$, the product is V .

Note that $\Lambda = R_m/R_i$.

PART B. QUALITATIVE DESCRIPTION AND PHYSIOLOGICAL IMPLICATIONS OF THE THREE-DIMENSIONAL SPREAD OF CURRENT IN CELLS

I. DISCUSSION APPLICABLE TO ALL CELL GEOMETRIES

I.1. *The Approximate Nature of One-dimensional Theory*

If a microelectrode is inserted into a cell, and for the present discussion we shall consider it to be a long cylindrical cell like an unmyelinated nerve fiber or a muscle fiber, we can inject current into the cell. This current will flow down the cytoplasm (filling the interior of the fiber) and eventually leak out through the fiber membrane and thence through the extra-cellular fluid to some reference or ground electrode. Associated with this flow of current are potential gradients both within the cytoplasm and across the cell membrane and these can be measured by inserting a second microelectrode at various distances along the fiber, away from the current electrode. For example, a known quantity of current, ΔI , can be injected and the displacement in

potential, ΔV , produced at a point in the fiber close to the site of injection of current can be measured with the second microelectrode. The ratio, $\Delta V/\Delta I$, is called the input resistance, R_p .

It is clear that the potential at any point within the fiber (with respect to the extracellular reference or ground electrode) must depend, in some way, on the resistivity of the cytoplasm and the resistance of the membrane. If the resistance presented by a given length of fiber membrane to current flow through it were relatively low, compared with the resistance presented by the cylinder of cytoplasm which the membrane enveloped, then current injected into the end of that length would leak out through the membrane rather than continue to flow along the cylinder of cytoplasm. Conversely, were the reverse the case, then current would continue to flow along the cylinder of cytoplasm rather than leak through the fiber membrane.

Thus, at any distance down the length of the fiber, current is flowing in two directions, (1) out through the membrane and (2) further down the cytoplasmic core of the fiber. The most commonly used theory which relates the input resistance, R_p , as defined above, to the resistance of the membrane in one unit length of the fiber and the resistance of the cytoplasm of one unit length of the fiber is called one-dimensional cable theory. In this theory, the assumption is made that the current flows in one direction only, namely, down the longitudinal axis of the fiber. That is to say, in any given small segment of length of the cytoplasm, the current which turns to leave the fiber through the membrane is negligibly small compared to the remainder of the current which continues to flow down the fiber. This assumes, therefore, that since negligible current is turning to leave the fiber in any small segment, the voltage gradients required to drive the current towards the membrane must be negligible. The only voltage gradients worth considering, then, are those associated with the major direction of current flow, the longitudinal voltage gradients. This means that the potential recorded by a microelectrode at any given distance down the fiber would not vary with the depth of the electrode tip within the fiber. In which case, one can therefore consider the cylinder of cytoplasm down which the current flows as a line, having a resistance per unit length equal to that of a unit length of a cylinder of cytoplasm. In many cases this is a reasonable assumption if we can show that little of the injected current leaves the fiber within a length which is large compared to, say, the diameter of the fiber. For example, if all the current left the fiber within a length equal to its diameter, then the direction of current flow would necessarily have to deviate considerably from its assumed one-directional flow. Whereas, if a distance equal to, say, twenty times the diameter of the fiber were required for the majority of the current to leave, then clearly one could say that the direction of current deviated only slightly from its assumed one-directional pathway.

There is thus, this one situation, at least, where the current must deviate, but perhaps not significantly, from its assumed one-directional pathway. However, there is one other, more important situation, where the current must flow in more than one direction. This is when the current leaves its

source which, more often than not, approximates a point source—the tip of a microelectrode. Whatever values the absolute resistances of the fiber membrane and cytoplasm have, the current must flow from the tip of the microelectrode in a variety of directions, at least for a short distance, before the current assumes its predominantly longitudinal path further down the fiber.

Clearly, these various directions of flow about the electrode tip will be associated with voltage gradients in these directions. It is these voltage gradients which drive the current away from a small source where the current density is high to fill the entire cross-section of the fiber and form a uniform flow of current of relatively low density further down the core of cytoplasm. These voltage gradients about the current source are, of course, neglected by one-dimensional cable theory.

There are two effects associated with these voltage gradients. One is that near the current source the potential recorded by a microelectrode at a given distance along the longitudinal dimension of the fiber will vary with the position of the electrode tip in the plane of cross-section of the fiber. Thus the true transmembrane potential can only be measured by placing the tip of the voltage electrode just beneath the fiber membrane. Secondly, close to the site of injection of current, the current density through the membrane is higher than would be predicted from one-dimensional cable theory. The same voltage gradients that are driving the current away from the point source cause the potential, just beneath the membrane, to be greater than one would expect if the current flowing down the fiber at that distance was uniformly filling the entire cross-section of the fiber. The longitudinal current density is, in fact, not uniform within any cross-section of the fiber sufficiently close to the current electrode.

One way of illustrating these two effects is to consider the fiber membrane to be almost a perfect insulator and, in order to allow some current to flow, we can imagine that we have a grounded microelectrode inside the fiber some considerable distance away through which the current can complete its circuit. Voltage gradients will occur about the current source, in all of the three dimensions within the fiber, which drive the current away from the source to eventually assume a uniform single, longitudinal direction of current flow further down the fiber. For example, if the tip of the current electrode were just beneath the membrane, the potential a sufficiently short longitudinal distance away on the same side of the fiber would be higher than it would be at a point the same longitudinal distance away but on the opposite side of the fiber (see Part A, Fig. IV.4-1). Similarly, equivalent voltage gradients develop about the distant grounded electrode as the current is squeezed into its tip. If we make the membrane leaky and replace the internal ground electrode with an external one, the situation is still qualitatively the same (with regard to the transmembrane potential), except that the higher potentials just beneath the membrane close to the tip of the current electrode, will now be associated there with the higher currents through the membrane compared with those at a point directly beneath the membrane on the other side of the fiber.

We therefore record potentials within the cytoplasm, immediately about the current source, which deviate in two ways from those predicted by one-dimensional cable theory. One is that the *true* transmembrane potential (i.e. that recorded by an electrode just beneath the fiber membrane) differs from that predicted by one-dimensional cable theory. Contrary to this theory, the true transmembrane potential varies with the circumferential position of the electrode tip relative to the current electrode. Secondly, the potential recorded by the voltage electrode when inserted deeper into the fiber differs from the true transmembrane potential because of voltage gradients in the cross-sectional plane of the fiber.

These effects of the three-dimensional spread of current away from the current source and the associated three-dimensional voltage gradients are qualitatively the same for any cell geometry. Indeed, for a point source of current, these gradients are always more important than those gradients which drive the current that is to leave the cell towards the cell membrane. For example, in a cylindrical cell, if we would replace the point source of current with a disc source, oriented in, and equal in area to, the plane of cross section of the fiber, the three-dimensional voltage gradients about the current source would become relatively insignificant and would be those associated with current turning to leave the fiber through the membrane (Taylor, 1963).

A quantitative assessment of the magnitude of the voltage gradients about a point source of current in a cell requires the solution of a mathematical problem which specifies the particular geometry of the cell. Because the solution of the problem becomes increasingly difficult (and eventually impractical) the more complex the geometry of the cell, solutions are available only for relatively simple geometries such as the cylindrical, spherical and the thick and thin plane cell. Nevertheless, it is clear that if the membrane resistance or impedance is sufficiently low, the current required to produce significant changes in the transmembrane potential close to the current source can be quite large. So large, that the potential differences in the cytoplasm associated with this flow of current from its source to the membrane become comparable with the displacement in transmembrane potential. Furthermore, in the same circumstance the displacement in true transmembrane potential close to the source depends on the position of the source relative to the membrane.

The reader is advised here to read section II (particularly II.1) of Part A, where we present a more extensive, but still qualitative, discussion of the errors in one-dimensional theory.

I.2. The Single Electrode Bridge and Double-barreled Microelectrodes

In this technique one microelectrode is inserted into the cell both to record potential and to inject current. The equivalent electrical circuit, with the microelectrode outside the cell, is shown in Fig. I.2-1A. The blunt end of the elec-

trode is connected to a current generator, S , and to a voltmeter, A . R_e represents the resistance of the microelectrode through which a constant current, I , flows from the generator, S . R_s (in series with R_e) represents the resistance to current flow from the tip of the microelectrode, through the extracellular fluid to a distant ground or reference electrode. We shall assume here ideal characteristics for the voltmeter, in that no current flows into or out of its input.

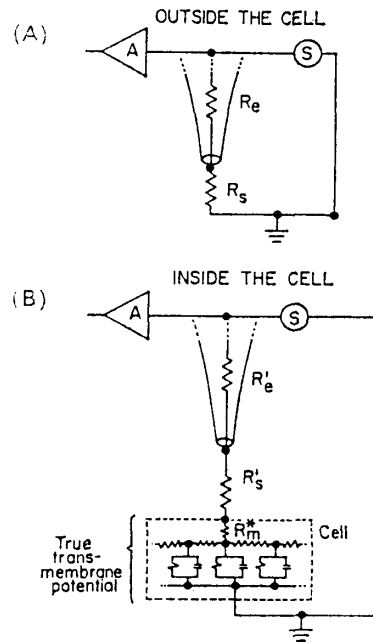

FIG. 1.2-1, (A and B). Equivalent circuits of a system using one microelectrode to record potential and to inject current.

(A) Outside the cell. (B) Inside the cell. In (A) R_e represents the resistance of the microelectrode when it is outside the cell; R_s represents the effective resistance presented to the flow of current from the tip of the microelectrode to the distant ground or reference electrode. In (B), R'_e represents the resistance of the microelectrode when inside the cell; R'_s represents the effective resistance presented to the flow of current from the tip of the microelectrode to the membrane in the immediate vicinity of the microelectrode (R'_s is zero when the electrode is just beneath the membrane). The series combination of R_m and the distributed one dimensional transmission line below it is a symbolic representation of the effects of three-dimensional spread of current on the *true* transmembrane potential. In both figures, S represents a current generator and A an ideal voltmeter.

The potential at the top or blunt end of the electrode, V , is simply given by $I(R_e + R_s)$. This voltage can be eliminated from the final recording either by the use of some bridge circuitry before the input to the voltmeter, or if the voltmeter can withstand the relative large voltage that will develop at the top of the electrode without changing its characteristics from the ideal (Murray, 1958), the voltage can be eliminated by the injection of a voltage of equal magnitude but of effectively opposite sign at a later stage in the recording circuitry. This accomplished, then presumably if R_e and R_s remain constant and an additional resistance were added in series with R_e and R_s , then

the voltage now recorded would be only the voltage drop produced by the current flowing through this additional resistance. Thus it has been argued that if the voltage V was eliminated (in either of the two ways described above) with the microelectrode outside the cell, and the microelectrode were then inserted into the cell, any voltage that was now recorded must be due solely to the insertion of an additional resistance, the input resistance of the cell, in series with the two resistances, R_e and R_s .

This argument assumes that R_n and R_s do not change when the electrode is inserted into the cell. However, at least R_s must change as we shall see below. Furthermore, in practice R_e usually changes for the following reasons. The major portion of the resistance of the microelectrode is located at its tip. Although the electrode is filled with a highly concentrated solution of electrolyte, usually with 3M KCl, the electrolytic composition of the liquid just within the tip, and hence its resistivity, quite probably depends on the composition of the medium in which the tip is immersed. One might expect therefore that the resistance of the microelectrode will change when the tip is moved from the extracellular fluid into the cytoplasm. Furthermore, the resistance of the electrode can be a bizarre and unpredictable function of the current flowing through the electrode and of time.

However, if in practice it were fortunately true that R_e remained constant as we moved the tip into the cell and when current was passed, there still remains the question whether we can assume that R_s remains constant. We cannot, since there are two factors that cause R_s to change. The value of R_s depends on the resistivity of the medium in which the electrode is immersed, so that as we move the electrode from the extracellular fluid which has a volume resistivity of approximately 50[ohm][cm], to the cytoplasm, which for muscle has a resistivity of around 300[ohm][cm], R_s will increase correspondingly (Schanne *et al.*, 1966). Secondly, when the electrode was outside the cell, current could flow in all directions away from the tip whereas within the cell the pathway of the current is constrained by the presence of the neighboring cell membrane. This restriction appears as an increase in the value of R_s over and above that expected from a simple change in the resistivity of the medium in which the tip is immersed.† A new equivalent circuit can be drawn for the situation where the microelectrode is in a cell (see Fig. I.2-1B). In this circuit the possible change in R_e is indicated by the prime, R'_e , and the change in R_s brought about by the two factors discussed above is indicated by the prime on R_s , R'_s .

In addition to the change in R_s to R'_s because of the change in the resistivity of the medium in which it is immersed and of the restriction in the pathway of current flow produced by the geometry of nearby cell membrane, another series resistance, R_m^* , appears, which represents the steep rise in true transmembrane potential immediately about the current source.‡ Although

† This further change in R_s may well explain the discrepancy found by Schanne *et al.* (1966) between values of input resistance measured by different techniques.

‡ This resistance R_m^* is the electrical equivalent of the mathematical term S (for $r = r' = a$) discussed in section IV. 3 of Part A.

physically, no such resistor exists, we can say, for qualitative description, that the membrane about the electrode tip behaves as though such a resistor were present as part of the membrane resistance and as such contributes to the true input resistance of the fiber. That is to say the voltage drop produced by current flowing through this resistance, R_m^* , is part of the true trans-membrane potential and ideally it should be preserved in any procedure that is devised to eliminate the voltage drops across the other resistances, R_e' and R_s' , in series with the membrane.

The results of our three-dimensional analysis in Part A show that the magnitude of R_m^* and R_s' in Fig. I.2-1B will, in effect, vary with the position of the current electrode and its relation to the tip of the voltage electrode. The single electrode bridge is the special case where the site of injection of current is also the site at which the potential is measured.†

Our previous analysis shows that R_s' will be zero when the tip of the electrode is just beneath the membrane. On the other hand R_m^* in this circumstance is not zero, in fact it never is whatever the position of the electrode within the cell. In practice, there are two methods for separating the voltage drops across R_e' , R_s' and R_m^* from that across the membrane resistance, R_m , but unfortunately they do not allow the preservation of that across R_m^* . The methods are based on measuring the voltage, V , either (a) when the membrane resistance is negligibly small compared to R_e' , R_s' and R_m^* or (b) when the membrane impedance is, similarly, negligibly small (e.g. when the frequency of the applied current is sufficiently high).

If a step of current is passed through the microelectrode the frequency components within the waveform which are important at its start are sufficiently high that the membrane impedance represented by the parallel combination, R_m and C_m , of Fig. I.2-1B is sufficiently low that the entire potential, V , at the top of the electrode at this time can be ascribed to the voltage drop across R_e' , R_s' and R_m^* . Physically, at this time, the membrane current density close to the current electrode is much greater than at later times since the rate of change of potential across the membrane capacitance is initially much greater than at later times. At the start of the current pulse, therefore, not only is there a voltage step caused by the current flowing through R_e' and R_s' but the true transmembrane potential undergoes an initial fast rising step simulated in Fig. I.2-1B by the voltage drop across R_m^* . This initial step then inflects with a slower component that has the familiar erf-like form of the response of a one-dimensional cable.

Eliminating the voltage at the start of the pulse thus removes all components of resistance in series with the membrane including that which represents a true change in transmembrane potential at that time. In effect we measure the displacement in potential predicted by one-dimensional cable theory.

† In addition the source of current at this site in this case is not a point but a small disc the diameter of which is equal to the diameter of the tip of the microelectrode. We assume that our analysis, of the two electrode case, correctly describes the qualitative properties of the one electrode case.

If one eliminated the voltage "artefacts" in this way, one might think that one could study the membrane properties, R_m and C_m . In fact if R_m remained high and constant everywhere, then after the initial jump in potential the subsequent slower, erf-like, change in potential does represent the simple membrane properties of a one dimensional cable. However, part of the initial jump in potential recorded by a single or double barreled electrode system is a true displacement in transmembrane potential. This initial displacement can be quite large, enough to drive the membrane near the electrode into a non-linear region of its current-voltage relationship, and thus making linear analysis impossible.

The second method of eliminating the voltage drops in series with the membrane is to assume that at some time during the action potential the membrane resistance is insignificantly small compared with the membrane resistance at some other time at which one wishes to measure it. At this time when the membrane resistance is low, any potential that is measured is solely due to voltage drops across resistances (R'_e , R'_s , and R_m^*) in series with R_m , at which time these voltage drops can be eliminated. Providing that these resistances remain constant, any additional voltage which develops at earlier or later times can be assumed to be the displacement in membrane potential at that time. The procedure is to apply a steady, small hyperpolarizing current some time before the initiation or appearance of an action potential and to continue the application throughout and beyond the duration of the action potential. The bridge is balanced or a sufficient voltage injected at an appropriate point in the recording circuitry, such that there is no voltage displacement at, say, the crest of the action potential. A discussion of how to choose the time during the action potential at which the input and hence membrane resistance is least is described elsewhere (Johnson and Tille, 1960, 1961).

The case of double-barreled microelectrodes is similar to the single electrode except that the voltage artefact to be eliminated is much less for a given current and microelectrode resistance since the tip of the electrode barrel which is used to record potential is a small, but significant, distance from the tip of the barrel used to inject current. However, although smaller, the same difficulties and uncertainties arise with regard to the separation of the voltage drop across the membrane from that across the outer resistances in series with it.

A further word of caution is required in regard to the elimination of the voltage "artefact". If the methods described above are applied indiscriminately to cells of more complicated geometry one may lose important features of the electrical properties of the system. For example, part or all of the membrane may be in series with a discrete lumped resistance, as in the case of crab muscle fibers (Eisenberg, 1967), or a distributed resistance as in frog skeletal muscle fibers (Falk and Fatt, 1964). Furthermore, if the cell geometry approximates the case where current is injected into a cylindrical cable that is terminated a short distance away by a bunch of similar but long cables, then the system will tend to behave as though a discrete resistance additional to those already discussed were in series with the membrane

(Johnson and Sommer, 1967). In each case, important properties would thus be lost in carrying out the procedures described above for eliminating the voltage artefact.

Out of the preceding discussion arises a convincing explanation of the finding that a cell can withstand the injection of a large current into it, provided that the current is increased slowly to its final large value. On the other hand, if the same current is injected suddenly in the form of a large step the cell is irreversibly damaged: there is a sudden diminution of the resting potential and amplitude of the action potential. The most likely reason for this is that at the start of the step, the membrane "impedance" is very low, the effective length constant short, and thus three-dimensional effects are important. The current density through the membrane about the current electrode becomes so large that the resulting steep rise in transmembrane potential is enough to exceed the dielectric strength of the membrane with consequent breakdown of the membrane dielectric.

I.3. *Voltage Gradients in Extracellular Space*

In our analysis of the three dimensional flow of current within the cell we made a very important assumption, namely, that the potential at any point in extracellular space with respect to any other point in that space remained constant. That is, no voltage gradients existed in that space. This is obviously impossible, physically, since if there are no voltage gradients there can be no current flow. During the propagation of an action potential or when current is injected into the cell, the extracellular space forms part of the path taken by the current and there must therefore be potential differences in this space.

The exact analysis of these external potential differences have been performed for a few simple geometries by Carslaw and Jaeger (1959), but the solutions are considerably more unwieldy than those for the internal potential differences which are considered here (see Part A).†

Because we cannot obtain an exact analysis, we are restricted to a qualitative discussion, and for this purpose we shall consider a cylindrical cell in a large volume of electrolyte. If that current which is injected into the cell flows for a distance many times greater than the diameter of the fiber, before most of it leaks out through the fiber membrane, then the fiber will behave like the classical one-dimensional cable. In other words, the length constant is many times greater than the fiber diameter and the current within the fiber is almost flowing in just one direction, longitudinally down the fiber. In which case, the potential gradients in the external medium are small, whereas if this is not the case and there are significant radial components in the direction of flow of cytoplasmic currents, then the potential gradients in the extracellular space may not be negligible.

Some insight can be gained into how this comes about by considering the

†We have recently come across a full three-dimensional solution including external potential drops in Weber (1873), reproduced by Weinberg (1942), pp. 112-13. The solution is indeed formidable.

fiber as a current source with respect to the external reference or ground electrode. For instance, if the length constant is very much bigger than the fiber diameter, the current leaves the fiber over a relatively long length. In this case, as a rough approximation, the fiber looks like a cylindrical current source of a constant current density and of a length equal to a length constant. On the other hand, when there is a significant radial component of current flow within the fiber, the length constant is necessarily short, comparable or smaller than the diameter of the fiber. The current source in this case appears much smaller, in the extreme it looks like a ring. In the external medium, the current density is thus much higher and the potential gradients become much greater about this smaller source and can become significant.

I.4. *Voltage Clamp with Two Microelectrodes*

The purpose of the voltage clamp technique is to measure the current that is required to hold the potential across a prescribed area of cell membrane uniform, both with respect to distance and to time. This current need not necessarily be equal to that injected into the whole system. In the relatively ideal system where a central axial wire assures the spatial uniformity of potential within the axoplasm, e.g. the experiments of Hodgkin, Huxley and Katz (1952) on the squid giant axon, the current injected into the axon was not measured. Rather a guard system was used which isolated that area of membrane where spatial uniformity of potential was assured and the current flowing through this guarded area of membrane was that measured.

When two microelectrodes are inserted into a cell, one to record potential and the other to inject current, we cannot assume spatial uniformity of potential near the current electrode. Now this non-uniformity, as we have pointed out before, is qualitatively independent of the geometry and is a consequence of the small size of the current source. It is clear, at least in principle, that spatial uniformity of potential cannot exist when the current source is a microelectrode.

It is a truism to say that in the two microelectrode voltage clamp, the voltage that is being controlled is the voltage at the tip of the voltage electrode and this voltage cannot be assumed to be the same as the true transmembrane potential. Indeed, when large currents are required to control the membrane potential during periods of high membrane conductance, the problem is not simply one of losing spatial uniformity in the true transmembrane potential in the area of interest, but one of measuring the true transmembrane potential correctly even at one point in this area. During such periods there are large voltage gradients within the cytoplasm which cause the potential recorded by the voltage electrode to depend on the depth of the electrode within the cell and the angular position of the electrode relative to the current electrode.

If the spatial non-uniformity in true transmembrane potential about the current electrode is such that the membrane there is not driven into a non-linear region of its current-voltage characteristic then the potential can be calculated, for the case of cylindrical cell, by use of the appropriate tables and

equations in Part A, section IV, where the three-dimensional spread of current within a cylindrical cell is analysed.

However, it would seem that in most cases of interest, sufficient current is being injected into the cell to make the steep rise in true transmembrane potential about the current electrode quite marked, and such as to make the assumption of linearity of the membrane current-voltage characteristic near the current electrode untenable. In this case, regenerative conductance changes could come about near the current electrode, greatly complicating the interpretation of the current voltage relationship, if not causing, (in conjunction with the electronic feedback system), uncontrolled oscillations in membrane potential.

II. THE CYLINDRICAL CELL

II.1. *The Optimum Electrode Separation within a Cylindrical Cell*

From our analysis of the three dimensional spread of current within the cylindrical cell it became clear that at small electrode separations, as is required when the experimenter wishes to measure the input resistance of such a cell, the potential that will be recorded, particularly when the length constant is small, will differ considerably from that predicted by one dimensional cable theory. Although the value of this potential displacement divided by the magnitude of the current injected, indeed, gives a true input resistance, R_p^* its value cannot be equated with the value R_p given by one-dimensional theory.†

$$\frac{V_0}{i_0} = R_p = \frac{1}{2} \sqrt{r_m r_i} = \frac{1}{2} \sqrt{\frac{R_m R_i}{\pi a^3}} \neq R_p^* \quad (\text{II.1-1})$$

Depending on the angular separation of the tips of the two microelectrodes and the distance separating them along the longitudinal axis of the fiber, the potential will either be greater or smaller than that predicted by one-dimensional theory. Hence, were the recorded potential used to evaluate an input resistance, this resistance, if substituted into equation (II.1-1) would lead to either an overestimate or underestimate of the specific membrane resistance of the fiber. From the three-dimensional analysis in Part A of this article, it was found that the recorded potential, V , could be thought of as the sum of two components. One component, given by $L(x, r_m)$, was identical to the classical one-dimensional expression for the spread of potential along the longitudinal axis of the fiber:

$$L(x, r_m) \equiv \frac{1}{2} i_0 (r_m r_i)^{\frac{1}{2}} e^{-x/\lambda} \quad (\text{II.1-2})$$

where current is injected in the middle of a fiber of semi-infinite length and

$$\lambda = (r_m/r_i)^{\frac{1}{2}}$$

†Where r_m is the resistance of the membrane in one unit length of the fiber and r_i is the resistance of one unit length of cytoplasm, R_m is the resistance of 1 cm² of membrane and R_i is the volume resistivity, of the cytoplasm of the fiber and a is its radius. i_0 is the current injected at $x = 0$ and V_0 is the hypothetical potential predicted at $x=0$ in one-dimensional cable theory.

The second component, given by $S(x,\theta)$, described the effects of the three-dimensional spread of current in the cell. This second term was found to be independent of the membrane properties, provided that the length constant was not smaller than the fiber diameter. Hence it is constant at any position x, θ , relative to the current electrode. Restated, the complete equation describing the spread of potential within a cylindrical cell about a point source of current is:

$$V(x,\theta) = L(x,r_m) + \frac{r_i a}{2} S(x,\theta) \quad (\text{II.1-3})$$

Our problem here is to devise some experimental technique to eliminate or conceal the effects of the second term in equation (II.1-3) so that we can determine the hypothetical potential, V_0 , which can be used in the one dimensional equation (II.1-1). One method would be to measure the potential at several points along the fiber, away from the current electrode, take the logarithm of these values and plot them against the corresponding values of x . Since the value of $S(x,\theta)$ in equation (II.1-3) becomes negligible at relatively large values of x , the one-dimensional term in this equation dominates and the plotted points will fall along a straight line with slope $1/\lambda$ (for detailed discussion see Falk and Fatt, 1964). The line is extrapolated back and the point at which it intercepts the voltage axis at zero x gives the voltage we need to compute the required input resistance. This, voltage, it must be remembered, is not the true membrane voltage at zero electrode separation, or, for that matter, at small finite electrode separations. However, it is the hypothetical voltage that is given by equation (II.1-1) and which can be used, together with the values of R_i and radius, a , of the fiber, to compute the value of the specific membrane resistance, R_m .

In order to describe our second method to determine the hypothetical voltage, V_0 , for which equation (II.1-1) is true, we need to reconsider the one-dimensional cable equation. If the electrodes are a finite distance apart, then the potential displacement given by this equation falls short of the value for $x = 0$. This is not a trivial point and we can illustrate it with an example. If the length constant is 1 mm, and the electrode separation is 100μ , not unrealistic values for many circumstances, the potential recorded at this small electrode separation falls 10% short of the theoretical value for $x = 0$, and the discrepancy of course is greater for smaller length constants and greater electrode separations. The first method described above not only allows us to circumvent the effects of the three-dimensional spread of current but allows us to obtain a closer estimate of the potential for zero electrode separation to be used in equation (II.1-1).

Our second method of obtaining the potential, V_0 , to be used in equation (II.1-1) is to make use of the effects of three-dimensional spread of current. We now recall that the three-dimensional correction term in equation (II.1-3), $S(x,\theta)$, has positive values for moderate angular and longitudinal positions of the electrode relative to the current electrode. Now let us suppose that we could determine a position for the voltage electrode such that the positive

value of the correction term, $S(x, \theta)$, exactly equals the decrement in potential (because $x \neq 0$) predicted by one-dimensional theory (i.e. the first term in equation (II.1-1)). Even though we do not measure the membrane potential displacement at zero electrode separation, as one-dimensional cable theory dictates, we could with this trick, measure the potential that this theory would predict at zero separation. We accept the fact, therefore, that there are effects due to the three dimensional spread of current within the cell and make use of them to allow us to determine the potential we would measure if the current came from an infinite plane source or less than ideal, a disc that filled a cross section of the fiber, in other words, the three-dimensional effects of current spread did not exist. We, in effect, make a real cylindrical cell behave like an imaginary, one-dimensional cell.

Restating equation (II.1-3)

$$\frac{V(x, \theta)}{i_0} = R_p^* = \frac{1}{2} \sqrt{r_m r_i} e^{-x/\lambda} + \frac{r_i a}{2} \cdot S(x, \theta) \quad (\text{II.1-4})$$

Thus

$$\frac{R_p^*}{\frac{1}{2} \sqrt{r_m r_i}} = e^{-x/\lambda} + \frac{a}{\lambda} S(x, \theta) \quad (\text{II.1-5})$$

But e^{-z} is defined by the series sum

$$e^{-z} = 1 - z + \frac{z^2}{1 \cdot 2} - \frac{z^3}{1 \cdot 2 \cdot 3} + \frac{z^4}{1 \cdot 2 \cdot 3 \cdot 4} \cdots \quad (\text{II.1-6})$$

So that we can write an approximation to equation (II.1-5) thus

$$\frac{R_p^*}{\frac{1}{2} \sqrt{r_m r_i}} \doteq \frac{a}{\lambda} S(x, \theta) + 1 - \frac{x}{\lambda} - \frac{x^2}{2\lambda^2} \quad (\text{II.1-7})$$

The question now to be answered is, what values of x brings the right-hand side of equation (II.1-7) equal to 1. When the right-hand side of equation (II.1-7) equals 1 then $R_p^* = \frac{1}{2} \sqrt{r_m r_i}$ as we desired. This value of x is clearly

$$\frac{a}{\lambda} S(x, \theta) \doteq \frac{x}{\lambda} - \frac{x^2}{2\lambda^2} \quad (\text{II.1-8})$$

As a first approximation, for small values of x/λ , $R_p^*/\frac{1}{2}\sqrt{r_m r_i}$ would approach unity when

$$\frac{a}{\lambda} S(x, \theta) \doteq \frac{x}{\lambda} \quad (\text{II.1-9})$$

that is to say, when

$$\frac{x}{a} = S(x, \theta) \quad (\text{II.1-10})$$

At such a distance, x , and angle, θ , the calculated value of the input resistance, R_p^* from the measured value of potential $V(x, \theta)$ would come closest to equaling that given by $\frac{1}{2}\sqrt{r_m r_i}$ of one-dimensional theory. Note also that this position is independent of λ , that is to say, as a first approximation, it is independent of the membrane resistance or impedance should these change from measurement to measurement.

A better approximation is obtained by including an additional term in the series expansion of $e^{-x/\lambda}$, which gives

$$\frac{x}{a} = \left[1 - \frac{1}{2} \frac{a}{\lambda} S(x, \theta) \right] \left[S(x, \theta) \right] \quad (\text{II.1-11})$$

Using our first approximation, equation (II.1-10), we can see from Table 3 that for an electrode separation, $x/a = 0.5$, the angular position of the voltage electrode which would give a value of $S(x, \theta) = x/a = 0.5$ is between 22.5 and 45 degrees. A closer estimate is obtained by inspection of the curve $x/a = 0.5$ in Fig. IV.4-3 of Part A. This estimate is about 38 degrees. One could choose to have the electrodes in line with no angular separation and choose a value of $x/a = S(x, \theta)$. However, in this case, $S(x, \theta)$ varies steeply with x and slight errors in position make it difficult to use this technique.

III. THE A.C. CASE

III.1. *A Brief Description and Derivation of the Generalized Frequency-dependent Length Constant*

We have already indicated that although the solution we have obtained for the three-dimensional spread of potential within cells are steady-state solutions, we can nevertheless use these solutions to obtain non-steady-state solutions. The rationale and detailed description of how to perform this feat cannot be given here. But suffice it to say that we define new currents and voltages, which are uniquely related to the real physical currents and voltages, but which do not require functions of time to describe them. This method is that of the Laplace transform and with it, the non-steady-state solution of electrical problems, where the currents and voltages can be any function of time, are obtainable from the steady-state solution of the problem (Van Valkenburg, 1964).

However, let us restrict ourselves to a consideration of the case where we allow the membrane potential or the injected current to vary in time in a rather special way, namely as a sinusoidal function of time. When we do this, the impedance presented to current flow by the capacitive elements of the membrane is considerably simplified and is more easily analysed mathematically. Furthermore, if we consider only the peak values of the currents and voltages, recognizing that these may not occur at the same time, we can obtain with relative ease many of the qualitative features of the response of the system to, for example, a step or pulse of current, as well as some quantitative information with regard to the response to a steady sine wave of current.

We can illustrate this procedure by applying it to the steady-state solution for the one-dimensional cylindrical cell, in which the membrane behaves as a resistance and capacitance in parallel. The total membrane current, I_T is given by

$$I_T = V/R_m + C_m \cdot dV/dt \quad (\text{III.1-1})$$

If the imposed voltage is a sinusoid, i.e. $V = V_p \sin \omega t$ where $\omega =$ [radians] [sec⁻¹], ($\omega = 2\pi f$, where f is frequency [Hz]), then

$$I_T = \frac{V_p \sin \omega t}{R_m} + C_m V_p \frac{d(\sin \omega t)}{dt} \quad (\text{III.1-2})$$

$$I_T = \frac{V_p \sin \omega t}{R_m} + C_m V_p \omega \cos \omega t \quad (\text{III.1-3})$$

From equation (III.1-3) we can see that the capacitive current, unlike the resistive current, varies with frequency. When the frequency is zero, i.e., at d.c., all the current through the membrane is resistive, whereas at a sufficiently high frequency, almost all the membrane current is capacitive and out of phase with the applied voltage. In our analysis here, we shall only consider the peak values of the voltages and currents and relinquish the fact that they do not occur at the same time. However, we can only do this after we have added up all the currents and voltages in the problem, and since we cannot add, for example, two sinusoidally varying currents unless we know the phase relationships between them as well as their peak values, both phase as well as amplitude of the voltages and current must be considered. In order to prepare the steady-state solutions to give us the peak value of the sinusoidally varying transmembrane potential, we first replace the membrane resistance, r_m by the membrane impedance, z_m . Now since the membrane impedance must contain enough information to enable us to recover the ratio of two time varying functions (the ratio of the membrane voltage and the injected current) the quantity that described the impedance, the impedance function, must contain information with regard to the time relationship between the two quantities (phase), as well as to their magnitude. We shall, therefore, not be so surprised to learn that the impedance is not given by one number but by a pair of numbers, a complex number. Such a number consists of two parts, one which is called the real part, a , and the other, the imaginary part, jb , where $j = \sqrt{-1}$ the whole number being written as the pair, $a + jb$.†

†The reader should be reminded that the nomenclature of complex numbers is most unfortunate: the numbers are not “complex” in the sense that they are complicated, since in fact they follow rules very similar to those applicable to ordinary numbers. Furthermore, the “imaginary” part of a complex number is fully as significant as the “real” part; and may have just as much physical meaning. Finally, it should be pointed out that the phase and amplitude of a complex number do have separate physical significance; in the case of the complex impedance one (phase) describes the time relation between current and voltage, the other the amplitude relation. However, the phase and amplitude of the impedance are not the same as the real and imaginary parts of the impedance, and indeed both the real and imaginary parts must be used in calculating phase and amplitude.

Thus, we replace the quantity r_m , which is given by an ordinary number, by the membrane impedance, z_m , which is described by a complex number. In doing so we shall find that we have factors and/or exponents in the equation which contain products, ratios, square roots, etc., of ordinary and complex numbers. The next step is to perform the complex algebra, following the rules for the arithmetical manipulation of complex numbers, so that we have a single complex number where we had originally ratios, products, square-roots, etc.

Taking the steady-state solution of the one-dimensional cable equation, as an example,

$$V = \frac{1}{2}i_0 \sqrt{r_m r_i} e^{-x/\sqrt{r_m/r_i}} \quad (\text{III.1-4})$$

where the factor in the exponent $(r_m/r_i)^{\frac{1}{2}}$ is usually called the d.c. length constant, λ .

Replacing r_m by z_m in equation (III.1-4), we get,

$$V = \frac{1}{2}i_0 \sqrt{z_m r_i} e^{-x/\sqrt{z_m/r_i}} \quad (\text{III.1-5})$$

However, we know that, in general, $(z_m/r_i)^{\frac{1}{2}}$ will be a complex number. Thus $(z_m/r_i)^{\frac{1}{2}}$ in the exponent of equation (III.1-5) cannot, in general, have the same significance as $\lambda = (r_m/r_i)^{\frac{1}{2}}$ in the exponent of the steady-state equation. In the latter, λ is a real number which gives the length at which the potential displacement has declined to $\exp(-1)$ of its value at the site of injection of a steady current. Since length can only be described by a real number, the complex number $(z_m/r_i)^{\frac{1}{2}}$ cannot have the same meaning. The, in general, complex nature of the exponent in equation (III.1-5) is best recognized by putting it in the form of the product of the real number, x , and a complex number, γ , where $\gamma = \alpha + j\beta$. The name given to γ in transmission line theory (King, 1965) is the propagation constant since it contains information as to the way the phase as well as the amplitude of the potential varies with distance down the fiber. The name of α is the attenuation constant and that of β , the phase constant.†

The question now arises as to whether we can define a quantity similar to λ of the d.c. solution. That is to say, can we define a length, λ^* , at which the peak value of the sinusoidal displacement in transmembrane potential declines to $\exp(-1)$ of its value close to the site of injection of current. Analysis shows that we can, as was first pointed out in the physiological literature by Falk and Fatt (1964), and this length, λ^* , is given by the reciprocal of the real part (R.P. denotes real part), of the complex number, $\gamma = \alpha + j\beta$. So that

$$V_p = i_p (\bar{z}_m r_i)^{\frac{1}{2}} \exp(-x/\lambda^*) \quad (\text{III.1-6})$$

† At d.c., the attenuation constant $\alpha = 1/\lambda$ where λ is the physiologists' measure of attenuation. It is, we think, unfortunate that this additional constant λ , was defined since at other than d.c. it does not give attenuation nor is there a simple relation between $1/\lambda$ and α and β of transmission line theory. Indeed the propagation constant, γ , is defined such that the attenuation is given by $\exp(-\alpha x)$ at all frequencies.

where V_p is the peak value of sinusoidal voltage, similarly for i_p . \bar{z}_m is the magnitude of the impedance and

$$\lambda^* = \frac{1}{\alpha} \quad (\text{III.1-7})$$

and furthermore,

$$\lambda^* = \frac{1}{\alpha} = \frac{1}{R.P. \left[\sqrt{\frac{r_i}{z_m}} \right]} \quad (\text{III.1-8})$$

The reader should be warned that because of the rules of complex algebra,

$$\frac{1}{R.P. \left[\sqrt{\frac{r_i}{z_m}} \right]} \neq R.P. \left[\sqrt{\frac{z_m}{r_i}} \right] \quad (\text{III.1-9})$$

To simplify the complex algebra that is involved, we shall take the case where the frequency of the applied current is sufficiently high that the membrane current is largely capacitive, that is to say, the membrane impedance, z_m , is simply that of a capacitor, which is $1/j\omega c_m$.

Substituting this expression for z_m in equation (III.1-5), we get

$$V_p = i_p \cdot \frac{1}{2} \sqrt{\frac{r_i}{j\omega c_m}} e^{-x\gamma} \quad (\text{III.1-10})$$

where

$$\gamma = \left[\frac{1}{j\omega c_m r_i} \right]^{\frac{1}{2}} \quad (\text{III.1-11})$$

Simplifying equation (III.1-11) using the rules of complex algebra, we get

$$\gamma = \alpha + j\beta = \left[\frac{\omega c_m r_i}{2} \right]^{\frac{1}{2}} + j \left[\frac{\omega c_m r_i}{2} \right]^{\frac{1}{2}} \quad (\text{III.1-12})$$

So that

$$R.P. [\gamma] = \alpha = \sqrt{\frac{\omega c_m r_i}{2}} \quad (\text{III.1-13})$$

For this particular case, where the frequency of the applied current is so high that $z_m = 1/j\omega c_m$, then the length constant, λ^* , is given by

$$\lambda^* = \frac{1}{\alpha} = \sqrt{\frac{2}{\omega c_m r_i}} \quad (\text{III.1-14})$$

or

$$\lambda^* = \sqrt{\frac{1}{\pi f c_m r_i}} \quad (\text{III.1-15})$$

From this expression one can see that the length constant has a value (in fact a maximum value if the membrane has no inductive elements) at d.c., given by λ . As the frequency of the applied current is increased the length constant decreases, approaching, at sufficiently high frequencies, in the case of a simple parallel arrangement of resistance and capacitance, the value λ^* , given by $(1/\pi f c_m r_i)^{\frac{1}{2}}$. Thus we can use this equation to assess whether, at a given frequency, the three-dimensional spread of current within the cylindrical cell is of importance. The value of λ^* can be calculated, and the ratio λ^*/a obtained. Table 2 lists the factor by which the voltage predicted by one-dimensional cable theory must be multiplied to give the voltage predicted by three-dimensional cable theory, for various values of the ratio λ^*/a of interest.

If the waveform of the injected current is not a steady sinusoid but a step, pulse or ramp then a useful rule of thumb is that fast rates of change correspond to high frequencies. It can be shown that, in fact, any waveform of current (or voltage) can be described by a series of sine waves of differing frequencies and amplitude of varying phase relationships to one another. For example, with this rule, we can see, qualitatively that during the start of a step of current the effective length constant can momentarily become very small and hence the displacement of true transmembrane potential can deviate considerably from that predicted by one-dimensional theory. This idea of a frequency-dependent length constant is one that it is well to keep always in mind for with the rule of thumb referred to above one can deduce many of the qualitative features of the spread of current within a cell, without performing a complete analysis.

IV. THE SPHERICAL CELL

The mathematical analysis of the effects of the three-dimensional spread of current within a spherical cell was not successful in that we could not sum a series and so were unable to calculate the magnitude of the three-dimensional effects. However, as in the case of the cylindrical cell, our analysis showed that the potential at any point within the cell (with respect to the outside) was given by an expression which separated into two terms.

$$V(r, r', \theta) = F(R_m) + G(r, r', \theta) \quad (\text{IV.1-1})$$

where r is the radial position of a point source of current, r' is the radial position of the point at which the voltage is measured and θ is the angular separation of these two points. One term, $F(R_m)$, is identical to that which one would obtain if it was assumed that the current caused no potential gradients within the cytoplasm in its passage from the current source to the membrane. The second term, $G(r, r', \theta)$, depends solely on the resistivity of the cytoplasm and accounts for such potential gradients. As for the cylindrical cell, for any given position of the voltage electrode relative to the current electrode, this term is constant in that as a first approximation it is indepen-

dent of membrane properties. The term which depends on membrane properties, is, the first term, $F(R_m)$. However, unlike the cylindrical cell, the only factor in the first term involving the membrane properties, is, the input resistance of the cell and this factor is not given by $\frac{1}{2}(r_m r_i)^{\frac{1}{2}}$ but simply by $R_m/4\pi a^2$. The absence of the square root in the case of the spherical cell therefore makes the magnitude of the first term very much more sensitive to changes in membrane properties, R_m (or Z_m). Thus we would predict that as R_m or Z_m decrease, the importance of the effects of the three-dimensional spread of current, that is to say the magnitude of the second term, $G(r, r', \theta)$, relative to the first, $F(R_m)$, would become noticeable at higher values of R_m or Z_m than in the cylindrical cell.

Hellerstein (1968) has analyzed the three-dimensional spread of current within a spherical cell about a point source of current and concludes that there are no potential gradients of any significance within the cytoplasm at any time. However, an analysis of his solution at small electrode separations does not support this conclusion (personal communication, E. Engel and R. S. Eisenberg).

REFERENCES

- ABRAMOWITZ, M. and STEGUN, I. A. (1967) *Handbook of Mathematical Functions*. National Bureau of Standards, 6th printing, Washington.
- ADRIAN, R. H., COSTANTIN, L. L. and PEACHEY, L. D. (1969) Radial Spread of Contraction in Frog Muscle Fibers. *J. Physiol.* **203**.
- CARSLAW, H. S. and JAEGER, J. C. (1959) *Conduction of Heat in Solids*, 2nd edition. Oxford University Press.
- COOLEY, J. W. and DODGE, F. A. (1966) Digital computer solutions for excitation and propagation of the nerve impulse. *Biophys. J.*, **6**, 583.
- EISENBERG, R. S. (1967) Equivalent circuit of crab muscle fibers as determined by impedance measurements with intracellular electrodes. *J. Gen. Physiol.* **50**, 1785.
- FALK, G. and FATT, P. (1964) Linear electrical properties of striated muscle fibres. *Proc. Roy. Soc. Series B*, **160**, 69.
- GRAY, A., MATHEWS, G. B. and MACROBERT, T. M. (1922) *A Treatise on Bessel Functions*, 2nd edition. MacMillan, London (Dover reprint available).
- HELLERSTEIN, D. (1968) Passive membrane potentials. *Biophys. J.* **8**, 358.
- HODGKIN, A. L. and HUXLEY, A. F. (1952) A quantitative description of membrane current and its application to conduction and excitation in nerve. *J. Physiol.* **117**, 500.
- HODGKIN, A. L., HUXLEY, A. F., and KATZ, B. (1952) Measurement of current-voltage relations in the membrane of the giant axon of *Loligo*. *J. Physiol.* **116**, 424.
- JOHNSON, E. A. and SOMMER, J. R. (1967) A strand of cardiac muscle: its ultrastructure and the electrophysiological implications of its geometry. *J. Cell. Biol.* **33**, No. 1, 103.
- JOHNSON, E. A. and TILLE, J. (1960) Changes in polarization resistance during the repolarizing phase of the rabbit ventricular action potential. *Aust. J. exp. Biol. med. Sci.* **38**, 509.
- JOHNSON, E. A. and TILLE, J. (1961) Investigations of the electrical properties of cardiac muscle fibers with the aid of intracellular double barrelled electrodes. *J. Gen. Physiol.* **44**, 443.
- KING, R. W. P. (1965) *Transmission Line Theory*. Dover Publications, N.Y.
- MORSE, P. and FESHBACH, H. (1953) *Methods of Theoretical Physics*. McGraw Hill, N.Y.
- MURRAY, C. T. (1958) A general purpose wide range electrometer. *Australian Atomic Energy Symposium*, Section 5: Instrumentation, p. 701 (Canberra).
- NOBLE, D. (1962) The voltage and time dependence of the cardiac membrane conductance. *Biophys. J.* **2**, 381.

- OLVER, F. W. J. (1960) *Bessel Functions, Part III Zeroes and Associated Values*. Cambridge University Press.
- ONOE, M. (1958) *Tables of Modified Quotients of Bessel Functions*. Columbia University Press, N.Y.
- ROBERTS, G. E. and KAUFMAN, H. (1966) *Tables of Laplace Transforms*. Saunders, Philadelphia.
- SCHANNE, O., KAWATA, H., SCHÄFER, B. and LAVALEE, M. (1966) A study on the electrical resistance of the frog sartorius muscle. *J. Gen. Physiol.* **49**, 897.
- TAYLOR, R. E. (1963) Cable Theory, in *Physical Techniques in Biological Research* W. L. NASTUK, Ed. Vol. VI B, p. 219. Academic Press, N.Y.
- VAN VALKENBURG, M. E. (1964) *Network Analysis*, 2nd edition. Prentice-Hall, Englewood Cliffs, N.J.
- WEBER, H. (1873) Ueber die stationären Strömungen der Elektrizität in Cylindern. *J. für die reine und angewandte, Mathematik* **76**, 1.
- WEINBERG, A. M. (1942) Green's Functions in Biological Potential Problems. *Bull. Math. Biophys.* **4**, 107.
- WOODBURY, J. W. and CRILL, W. E. (1961) On the Problem of Impulse Conduction in the Atrium. In *Nervous Inhibition*, E. FLOREY, Ed. Pergamon Press Inc., N.Y.