

Dear all,  
Today I received notice from Frodo Ferro that our patent application on Ion transistor has been published now: the actual publication date is 29 July 2004.  
I collected the corresponding PDF file from Delphion, and attach it for your information & archive.

(For internal use: the file has also been placed on the H drive, under General info/patent information/BTF-ANS patent portfolio/Ion transistor).

Best regards,  
Greetje

Dr. Greetje H. Vos-Scheperkeuter  
Patent Coordinator  
Biomade Technology Foundation  
Nijenborgh 4  
9747 AG Groningen  
The Netherlands  
Tel. + 31 50 363 6966 (or: 5246)  
Fax + 31 50 363 4429  
Email vos@biomade.nl  
Web www.biomade.nl

\*\*\*\*\*

The information contained in this communication is confidential and may be legally privileged. It is intended solely for the use of the individual or entity to whom it is addressed and others authorised to receive it. If you are not the intended recipient you are hereby notified that any disclosure, copying, distribution or taking any action in reliance on the contents of this information is strictly prohibited and may be unlawful. BioMaDe Technology is neither liable for the proper and complete transmission of the information contained in this communication nor for any delay in its receipts.

WO04064091A1.pdf

(19) World Intellectual Property  
Organization  
International Bureau



(43) International Publication Date  
29 July 2004 (29.07.2004)

PCT

(10) International Publication Number  
**WO 2004/064091 A1**

- (51) International Patent Classification<sup>7</sup>: **H01G 9/00**
- (21) International Application Number:  
PCT/NL2003/000013
- (22) International Filing Date: 9 January 2003 (09.01.2003)
- (25) Filing Language: English
- (26) Publication Language: English
- (71) Applicant (for all designated States except US): **MOLECULAR BIOPHYSICS INC.** [NL/NL]; c/o Ardyth Eisenberg, 7320 Lake Street, Unit 5, River Forest, IL 60305-2231 (NL).
- (72) Inventor; and
- (75) Inventor/Applicant (for US only): **EISENBERG, Robert, Shim** [US/US]; 7320 Lake Street, Unit 5, River Forest, IL 60305-2231 (US).
- (74) Agent: **PRINS, A., W.**; Nieuwe Parklaan 97, NL-2587 BN Den Haag (NL).
- (81) Designated States (national): AE, AG, AL, AM, AT (utility model), AT, AU, AZ, BA, BB, BG, BR, BY, BZ, CA, CH, CN, CO, CR, CU, CZ (utility model), CZ, DE (utility model), DE, DK (utility model), DK, DM, DZ, EC, EE (utility model), EE, ES, FI (utility model), FI, GB, GD, GE, GH, GM, HR, HU, ID, IL, IN, IS, JP, KE, KG, KP, KR, KZ, LC, LK, LR, LS, LT, LU, LV, MA, MD, MG, MK, MN, MW, MX, MZ, NO, NZ, OM, PH, PL, PT, RO, RU, SC, SD, SE, SG, SK (utility model), SK, SL, TJ, TM, TN, TR, TT, TZ, UA, UG, US, UZ, VC, VN, YU, ZA, ZM, ZW.
- (84) Designated States (regional): ARIPO patent (GH, GM, KE, LS, MW, MZ, SD, SL, SZ, TZ, UG, ZM, ZW), Eurasian patent (AM, AZ, BY, KG, KZ, MD, RU, TJ, TM), European patent (AT, BE, BG, CH, CY, CZ, DE, DK, EE, ES, FI, FR, GB, GR, HU, IE, IT, LU, MC, NL, PT, SE, SI, SK, TR), OAPI patent (BF, BJ, CF, CG, CI, CM, GA, GN, GQ, GW, ML, MR, NE, SN, TD, TG).
- Published:**  
— with international search report
- For two-letter codes and other abbreviations, refer to the "Guidance Notes on Codes and Abbreviations" appearing at the beginning of each regular issue of the PCT Gazette.*

(54) Title: LIQUID BASED ELECTRONIC DEVICE

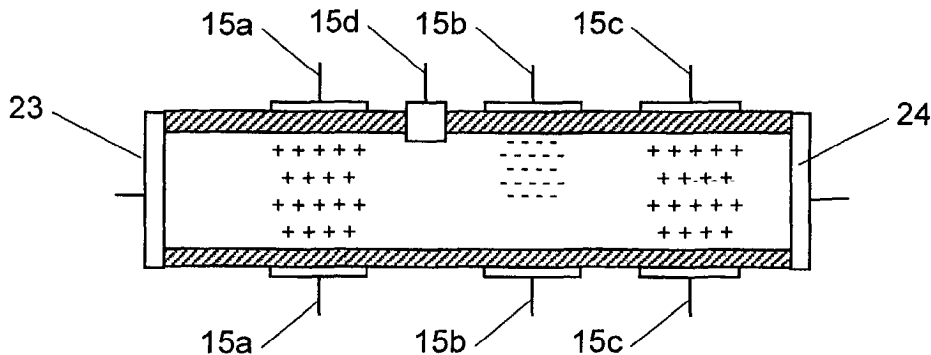

(57) Abstract: An electronic device, comprising: at least one channel with a fluid fillable channel interior and an electrically insulating wall surrounding at least partially the channel interior, which channel interior, in use, contains charge carriers, which electronic device further comprises: at least one control electrode, which electrode is electrically isolated from the channel interior and in capacitive contact with the channel interior. Furthermore, methods for use of such an electronic device, for example mixing or separating fluids.

WO 2004/064091 A1

## LIQUID BASED ELECTRONIC DEVICE

## TECHNICAL FIELD AND BACKGROUND OF INVENTION

The invention relates to an electronic device. The invention further relates to an integrated circuit comprising such an electronic device and methods using such an electronic device. The invention also relates to a control device for controlling electrical properties of an electronic device and a computer program product

A substantial part of modern technology is based on electronic devices that manipulate the flow of charge carriers, such as 'holes' and 'electrons', in solid state semiconductors, e.g. transistors and integrated circuits (IC). The flow of the charge carriers in those semiconductor devices is determined both by the physical properties ('state') of the semiconductor device and the state of the device terminals at which the voltage of (parts of) the semiconductor device is controlled and current is applied.

The physical properties of a semiconductor device are in turn determined in large measure by the profile of impurities ('doping') which determines the distribution of fixed charge, i.e. the charge that is (more or less) independent of the local electric field. The doping profile is built into the semiconductor device as it is made by rather elaborate chemical and physical processing and is inflexible. It is, more or less, impossible to alter the doping profile after manufacturing the device. The doping profile is an important determinant of the qualitative properties of the device, i.e. whether the device is a bipolar transistor, field effect transistor, silicon controlled rectifier, etc. Once manufactured, most of these devices cannot be converted from one type to another.

Most of the known semiconductor devices can be classified in substantially two classes, unipolar and bipolar. In an unipolar device the doping is of a single type, e.g. positive or negative. Examples of unipolar

devices are Metaloxide Semiconductor Field Effect Transistors (MOSFET) and Schottky-diodes. A bipolar device have opposite types of doping, e.g. positive and negative, which types may be placed in separate areas thus forming n-p junctions. Examples of bipolar devices are bipolar junction  
5 transistors and PN-junction diodes.

The physical state of the device terminals is determined for the most part by the voltage (and current) applied to them. The voltage and current can be easily controlled in time by a large range of analog and digital circuits which in turn can be controlled with high resolution by widely  
10 available integrated circuits in computer systems. The voltage and current can further be controlled in space by using an array of terminals, each of which receives a separate current and/or voltage, for example, from the output of an operational amplifier under computer control. The array of terminals in fact can be controlled by nearly the same circuitry and  
15 computer systems (hardware and software) that control gate arrays and memory chips. Using state of the art technology, the physical properties of the terminals are controllable in space and time on a scale of 10 nmeter and larger and 100 nsec and longer, using conservative estimates of technology available in 2002.

20 Although the state of the device terminals is easy to control, the other main determinant of the properties of a device—the state of the semiconductor itself, i.e., its doping profile—is hard to control. Despite the considerable sophistication of the known electronic devices, they have the important disadvantage of inflexibility. Once the doping profile is built into  
25 the semiconductor device during manufacture, it is difficult, if not impossible, to change the profile. The physical state of the semiconductor is determined once and for all when it is manufactured.

Besides semiconductor devices in which the main current carriers are holes and electrons, also devices are known in which ions in aqueous  
30 solution are the main current carriers. Both classes of devices have

advantages: electrons and holes are inherently very much faster, while ions allow chemical properties to be exploited. Ionic integrated circuits (IIC's) are devices in which a controlled flow of ions in solvents (chiefly but not exclusively water) is achieved. IIC's can be built that mimic solid state  
5 integrated circuits because the equations of ionic current flow are (nearly) identical to the equations of electron and hole current flow in semiconductors [1,8-16]. Where the properties of IC's are determined by the spatial distribution of doping governing the distribution of a fixed charge, the properties of IIC's can be determined for instance by the spatial  
10 distribution of fixed charge in a polymer matrix, along the wall of a protein channel or along the wall of a carbon nanotube. For example, if a fixed charge in either an IC or an IIC is positive in one region and then negative in the adjacent region, a PN junction diode is produced, which can be immediately recognized by its current-voltage characteristics.

15 However, IIC's too have the disadvantage that doping in the IIC is set once and for all when the device is made. The doping is a result of the physical and chemical structure of the device and so the doping in an IIC, like the doping in a semiconductor device, cannot be changed once the device is built.

20

#### SUMMARY OF THE INVENTION

It is a goal of the invention to provide a more flexible device and in particular a device with a temporal or spatial variable doping profile. Therefore, the invention provides an electronic device according to claim 1.  
25 A device according to the invention is flexible because the doping in the channel can be controlled via the charge or voltage on the electrode.

Furthermore, the invention provides an integrated circuit according to claim 24, and methods according to claims 25-28. Such an integrated circuit and methods are also flexible because the doping in the device used  
30 in the integrated circuit or methods is flexible.

The invention also provides a control device for controlling electrical properties of the control electrodes of an electronic device according to the invention. The invention also provides a computer program product comprising program code for performing steps of a method according to the invention when run on a programmable device.

Specific embodiments of the invention are set forth in the dependent claims. Further details, aspects and embodiments of the invention will be described with reference to the figures in the attached drawings.

## 10 BRIEF DESCRIPTION OF THE DRAWINGS

FIG. 1 schematically shows a cross-sectional view of an example of an embodiment of a device according to the invention.

FIG. 2 schematically shows a cross-sectional view of the example of FIG. 1 taken along line II-II.

15 FIG. 3 schematically shows a block diagram of the example of FIG. 1 connected to a control circuit.

FIG. 4 schematically shows a cross-sectional view of an example of an embodiment of a device with two channels connected to each other.

20 FIG. 5 schematically shows a cross-sectional view of an example of an embodiment of a device according to the invention used as a unipolar device.

FIG. 6 schematically shows a cross-sectional view of an example of an embodiment of a device according to the invention used as bipolar device.

25 FIG. 7 schematically shows a cross-sectional view of an example of an embodiment of a device according to the invention used as a bipolar device with current injection.

FIG. 8 schematically shows a cross-sectional view of an example of an embodiment of a device according to the invention which may be used for chemical reactions or catalysis.

FIG. 9 schematically shows a cross-sectional view of an example of an embodiment of a device according to the invention implemented in an integrated circuit

FIG. 10 schematically shows a cross-sectional view of an example of an embodiment of a device according to the invention with an annular shaped channel.

#### DETAILED DESCRIPTION.

In the following, the invention is explained in more detail with examples of devices and methods in which ions are the main type of charge carrier. However, the invention may likewise be applied in IC's with electrons and/or holes as the dominant type of charge carriers. Specifically, but not exclusively, in applications where speed is not the defining figure of merit the invention may be used with substantial advantages with respect to flexibility and control with electrons and holes as the main type of charge carrier. Furthermore, the term 'fluid' as used herein comprises any non-solid state medium, such as: a liquid, a gas, a (partial) vacuum, a plasma or otherwise.

In FIG. 1, an example of an embodiment of a device according to the invention is shown. The device comprises a channel 10 surrounded by an electrically insulating wall 11. The wall 11 has an inner wall surface 12 facing towards the channel interior 14 and an outer wall surface 13 facing away from the channel interior. On the outer wall surface 13, a number of electrical contacts or pads 15 is positioned. The pads 15 may be of a metallic or a semiconductor material and are electrically insulated from the channel interior 14, but in capacitive contact with at least a part of the channel interior 14. The pads are connectable via conductors or wires 18 to a control circuit, for example a control circuit as shown in FIG. 3.

In use of the device, charge carriers are present in the interior 14 of the channel 10. The charge carriers may for example be ions in a liquid,

such as an aqueous solution containing for example salt ions, such as Na<sup>+</sup> and Cl<sup>-</sup>. Via the conductors or wires 18, the charge or voltage of the pads 15 can be controlled. In the example of FIG. 1, each pad 15 is connected to a separate wire 18 and thus the voltage or charge on each pad can be  
5 controlled independent from the voltage or charge on the other pads 15. Thus for instance the left hand pair of pads 15 in FIG. 1 may have a voltage different from the voltage on the central pair, which again may differ from the voltage of the right hand pair, thus controlling the doping profile along the channel.

10 Because the charge or voltage on the pads is controlled, the electrical characteristics of the channel in the vicinity of the pads are controlled. More specific, in the example the pads 15 are in capacitive contact with the channel interior 14. Each pad 15 thus acts as a plate of a capacitor while the channel interior 14 near a pad 15 acts as a capacitor plate as well. The  
15 channel wall 11 acts as a dielectric between the capacitor plates, e.g. a pad 15 and the respective part of the channel interior 14. Hence, by changing the charge on or voltage of one of more pads 15, the channel interior 14 will perform its role as a capacitor plate and the voltage or charge in the channel  
20 is changed or said differently: a change is induced in the channel by the changing the charge on or the voltage of the pads (and hence a current is induced in the channel interior).

The induced charge in the channel acts like doping because it has the same effect on the electrical and diffusion properties (i.e., the electrochemical properties) of the channel as a fixed charge, (i.e. a doping),  
25 in the channel. Thus, via the charge on the pad, the charge in the channel and thus the doping of the channel is controlled and can be changed. Hence, in a device according to the invention the doping is flexible with respect to time and space because the charge or voltage on the pads is flexible.

The voltage on a pad may for example be controlled by connecting the  
30 pad to an amplifier device, which controls the voltage on the pad. For



example, the amplifier may be the output of a digital to analog converter (DAC). Reading a sequence of (binary) numbers into the input of the DAC gives a certain output voltage as explained above. Via the voltage on the pad, the voltage or charge in the channel is controlled and hence the doping  
5 of a device according to the invention. The sequence of (binary) numbers can be provided by widely available computer circuitry on a very rapid time scale.

In the example of FIG. 1, the channel interior 14 is in contact with reservoirs 17 via openings 16, as is indicated with the dot-striped lines in  
10 FIG. 1. The reservoirs 17 contain a fluid and ensure that the composition of the fluid in the channel remains substantially invariant over time. The channel of the example of FIG. 1 has a width of about a few Debye lengths  $\kappa^{-1}$  of the ionic solution in the channel ( $\kappa^{-1} \doteq 0.3/C^{1/2}$  in nmeter for a monovalent salt in water), however such a dimensioning is not strictly  
15 necessary. For the sake of clarity, the Debye length is a measure of the distance over which the electric charge is screened. In the screening process, mobile charges rearrange when a charge is inserted. The mobile charges within a few Debye lengths rearrange so they balance the inserted charge. Beyond a few Debye lengths the inserted charge and rearranged charge  
20 balance so the inserted charge is said to be screened.

In FIG. 2 a cross-section of the example of FIG. 1 is shown, taken along the line II-II in FIG. 1. The channel 10 has a substantially rectangular cross-section. The channel may likewise have a differently shaped cross-section, such as a triangular, circular or otherwise. As is shown in FIG. 2, the  
25 channel 10 is surrounded by pads 15, i.e. there are not only pads on what may be seen in FIG. 1 as the top and bottom wall of the device, but also on the side walls. Rather, the pads are on each side of the channel in FIGs. 1 and 2. In the example of FIGs. 1 and 2, pads which in circumferential direction of the channel are positioned on different places, but in the  
30 longitudinal direction (i.e. in FIG. 1 from one of the openings 16 to the other

opening) are positioned on the same place are all connected electrically and thus have the same electrical potential. This geometry makes the electrical potential inside the channel in a cross section of the channel more or less uniform and allows the device to function more simply, without the complexities introduced by an uncontrolled spatial variation in potential. However, it is likewise possible to implement pads at the same longitudinal position that are electrically separated from each other. In this case, the electrical field in the channel can be varied via the pads in a more flexible way, for example pads facing each other may be set to different voltages to separate positive and negative charge carriers from each other.

FIG. 3 shows a part of an example of a device according to the invention connected to a control circuit. However, an electronic device according to the invention may likewise be connected to another type of control circuit, for example a non-programmable dedicated hardware circuit or otherwise. The control circuit in FIG. 3 comprises a charge control device CC connected to the pads 15 via the wires 18. The charge control device CC is connected to a digital to analog converter device or DA-converter DAC. DA-converters are generally known in the art and the DA-converter may be of any type suitable for the specific application. The DA-converter may for example be of a type as is known from compact disc players, which are in general of a high quality and cheap. The DA-converter DAC is communicatively connected to a processor device 33 of a standard personal computer PC. In the example of FIG. 3, the personal computer PC has an input device, e.g. a keyboard 31, and an output device, e.g. a monitor or display 32. The keyboard 31 and the monitor 32 are communicatively connected to the processor device 33 in the personal computer PC. The processor device 33 is also communicatively connected to a memory device 34.

An operator of the electronic device 10 according to the invention may select via the keyboard 31 values of the charge or voltage to be applied to

one or more of the pads 15. The selected values are then processed by the processor device 33 and displayed at the monitor device 32, in the shown example as a matrix 35 with the selected values. The processor device 33 also transmits digital signals representing the values to the DA-converter. 5 The DA-converter converts the digital signals to analog control signals, for example as a voltage at one or more outputs of the converter. The analog control signals are transmitted to the control device CC and used by the control device CC to control the charge or voltage on the pads.

In the example of FIG. 3, the charge control device CC is arranged to 10 control the voltage on a pad 15 to maintain a constant charge on the respective pad and thus, ceterus paribus, a constant charge in the channel interior 14. As explained, the channel interior in the vicinity of a pad behaves like a region of doping. The value of that effective dopant charge can be varied by changing the charge or voltage on the pad by inputting a 15 different value via the keyboard 31. It is likewise possible to control the charge by running a computer program stored in the memory 34 on the processor device 33, which contains the values of the charge or voltage, optionally as a function of time and or space and controls the charge control device CC in correspondence with the values in the program.

20 The charge control device CC may be implemented in any way suitable for the specific application. Many different ways are known in the art to control the charge on each pad, ranging from the simple use of a large voltage that swamps variation in potential or capacitance in the channel, to feedback devices that sense and measure the capacitance from the pad to 25 the solution in the channel (for example using a four electrode method) and control the voltage on the pad to keep the charge constant. It should be noted that the charge  $Q = CV$ , with C representing the capacitance and V the voltage. Thus, the voltage V can be varied by a feedback circuit to keep the dopant charge Q constant at the desired value if the capacitance C is 30 measured or known. Because the current I is the time derivative of the

charge  $Q$ , the capacitance  $C$  is related to  $I/V$  and may for example be determined by superimposing on an off-set voltage a very small AC voltage and measuring the resulting AC current.

In an electronic device according to the invention, the distribution of the fixed charge may easily be changed by adjusting the charge on the pads, so the device can be easily changed from, for example, a PNP transistor to an NPN transistor or to a diode by inverting the charge type on the pads. Spatial and temporal control of doping are simultaneously available, because each spatially distinct pad can have its voltage (and thus charge) controlled as a function of time. In this way one and the same physical geometry can be switched from being a diode (for example) at one time, to a PNP transistor at the next time, to a PNPN thyristor and back and forth.

The example of FIG. 5, has two pads 15a positioned facing each other on the opposite sides of the channel, i.e. one pad lies on what may be seen as the top of the channel and the other pad on what can be regarded as the bottom. As shown in FIG. 5, the pads 15a can operate the device as a unipolar device, since only negative doping is present. The example of FIG. 5 can for example behave like a Field effect transistor, a MOS-capacitor, a Schottky-diode or otherwise. In FIG. 5, the channel has electrodes 23,24 which can inject a current into the channel. Thus, contrary to the pads 15a, the electrodes 23,24 are not separated from the channel by the electrically isolating wall of the channel but in conductive contact with the channel interior 14. The electrodes may for example be electrically connected to a suitable voltage or current source to provide the current to be injected.

Preferably, the electrodes 23,24 are reverse electrodes which provide a good current to flow from one of the electrodes 23 to the other electrode 24 or vice versa. The electrodes 23,24 are positioned at a distance from the pads 15a. Thus, unwanted interaction in the channel between the injected current and the charge or current induced by the pads is prevented. Such

unwante interaction may for example be changes in the doping profile by the voltage on the electrodes 23,24 or by the injected current or otherwise.

The charge on the pads of an electronic device according to the invention may likewise be controlled to set the electronic device to behave as a device of a different type than in the example of FIG. 5. For instance if the device has a multiple of pads, the device may be controlled to be a bipolar device or an integrated circuit comprising a multiple of devices connected in series or in parallel. For example in FIG. 6, the device has two pads 15a,15b on each of two opposite sides of the channel of which the left pad 15a is kept at a positive charge and the right pad 15b is kept at a negative charge, both independent of the potential in the channel. Thus, the electronic device of FIG. 6 according to the invention acts as a bipolar device, and more specific as a NP-diode with the N-P junction in the middle between the pads 15a ,15b. Therefore, if a current is injected at the electrode 24, which thus is the cathode contact of the diode (at the right in the FIG. 6), the device will conduct the current to the electrode 23, the anode contact (at the left in FIG. 6), i.e. the device acts as a diode in forward, while if a current is injected at the anode contact 23 the device acts as a diode in reverse, i.e. the device does not conduct the current.

In the example of FIG. 7, the charge on the pads 15a-15c is controlled such that the doping in the channel in the region of pad 15b in the middle is negative. The regions of the other two pads 15a,15c are positively doped. Near the pads 15b in the middle, a direct electrode 15d is present. The direct electrode 15d is in conductive contact with the channel and can inject a current in the channel interior. In FIG. 7 the direct electrode 15d is in direct contact with the channel interior and at least a part of the direct electrode lies physically in the channel interior. Thus, the device in FIG. 7 can act as a P-N-P bipolar junction transistor (BJT). When injecting a current at one of the electrodes 23, 24, the conductivity of the device may be controlled by the current injected with the direct electrode 15d and the

charge or voltage induced in the channel via the pads 15a-15c. By reversing the charges or voltages on the pads 15a-15c, e.g. switching the positively charged pads to a negative charge and vice versa, the device of FIG. 7 can for example be changed from a PNP BJT into a NPN BJT. When no current is injected via the direct electrode 15d, the device can for example act as a  
5 PN-diode connected in series with a NP-diode.

In the examples of FIGs. 6 and 7, P-N junctions are shown, however it is likewise possible to apply a different voltage or charge to the control electrodes, such that for example P-P++ junctions are obtained or no junction  
10 at all. In general, the electrodes can be used to obtain any charge distribution suitable for the specific implementation.

In a device according to the invention, the channel has length and thus can extend over an array of pads, while the charge or voltage of each pad may be separately controlled, for example because each pad is  
15 separately connected to its own amplifier and DAC. In such an array of pads, easily addressable access to each pad is available. A device according to the invention with an array of pads closely resembles a CMOS memory or a gate array chip. Simple computer programs can thus control the voltage on a spatial distribution of pads. Each pad is controlled to a voltage (and  
20 thus charge) set by a number stored in some memory location. In this way a single device having a certain physical geometry can be made into a variable series arrangement of devices of different types (e.g., PN diode in series with PNP transistor etc etc). All that is necessary is to read into each pad the appropriate voltage, and thus charge, i.e., doping. For example, in the  
25 simplest case, an amplifier holds the voltage constant and thus, as long as the capacitance does not change significantly, the charge will be constant and behave just as fixed charge.

The resolution of the spatial control is determined by the spacing between the pads. The temporal resolution is determined by the speed with  
30 which the voltage and charge on the pads may be varied. The ability to

create a doping profile is determined by the accuracy with which the amplifier can control the charge on the pad. If the capacitance is constant, that accuracy is determined by the output current of the amplifier and the “slew rate” that is the fastest speed at which an amplifier can change its  
5 output voltage, nowadays many volts per microsecond. If the capacitance between pad and channel interior varies significantly, additional circuitry may be provided to control charge, for example by varying the voltage on the pads as the capacitance changes.

A device according to the invention may be electrically connected to  
10 other devices, such as for example conventional solid state devices in which holes and electrons are the charge carriers. In such case, a device according to the invention may be combined with such solid state devices in a single integrated circuit. FIG. 9 shows a cross-sectional view of a device according to the invention suitable for use in an integrated circuit. The device in FIG.  
15 9 is implemented on a substrate 21, such as for example is known in the semiconductor industry as a ‘wafer’. The substrate 21 may for example contain Si, GaAs,  $Al_xO_y$  or otherwise. On the substrate 21 an electrically insulating material 22 is deposited, for example Silicon Oxide. In the insulating material 22 channels 10 are provided. The insulating material 22  
20 forms the walls of the channels 10. Near the channels, electrical contacts or pads 15 are situated which pads are electrically separated from each other and the channel 10 by the isolating material 22. The pads 15 are connected via connections 18 of a conducting material to other circuitry, such as for example MOS (Metal Oxide Semiconductor) devices or otherwise.

25 A device according to the invention can be built to be selective between different types of charge carriers, and for example discriminate between types of ions. For example, a polyelectrolyte with high charge density, such as a polymer like polyglutamate, may be placed in the channel, in which case the mobile ions will be crowded. Different ions  
30 behave differently when crowded (i.e., they have different free energies per

mole when at the same number density) because they have different diameter and charge. These crowded charge effects interact with the simple electrostatics of the IIC to produce controllable selectivity, as in natural biological ion channels. A device according to the invention with a  
5 polyelectrolyte acts as a rectifier for different types of ions, which chemical rectifier can be moved in space, allowing specific ions to be swept along from place to place. Similarly, a PNP arrangement in the presence of a polyelectrolyte in the channel will make a chemical amplifier just as it makes an electrical amplifier. Current flow can be carried by a wide range of  
10 ions and so selectivity of different ion types is possible under computer control in a device in accordance with the present invention. In this way, separation can be possible on a bulk scale, including the use of such devices for desalination.

A device according to the invention may contain a large number of  
15 channels in parallel. Thus, large amounts of current can be controlled even if the current in individual channels is small.

In the example of FIG. 4, two channels 10,10' are interconnected via cross channels or connections 19. In the example of FIG. 4, seen in a longitudinal direction of the channels, the connections 19 each are  
20 positioned between two pads 15. Via the connections 19, particles from one channel can be brought into the other. For example, if in the channel 10, water with Na<sup>+</sup> ions is present, while in the channel 10' only Cl<sup>-</sup> ions are present, the ions from the channel 10 may be inserted in the channel 10' by appropriate control of the charge on the pads 15. E.g., by putting the pads in  
25 the channel 10' near the opening on a negative potential, thus attracting the positive Na<sup>+</sup> ions. The connections 19 between the channels 10 may also be used to bring two reactants together in order to perform a chemical reaction and transport them further or lead them along a chemical reactant or catalyst, for example by implementing a part of one of the channels as is  
30 shown in the example of FIG. 8.



In the example of FIG. 4 channels are connected in a two dimensional manner, however layering technology allows the channels to be built and connected in three dimensions, giving an large increase in density and flexibility to the devices.

5 In the examples shown in FIGs. 1-7, seen in a longitudinal direction of the device, one, two or three sets of pads are positioned next to each other. However, it is likewise possible to provide a device according to the invention with a different number of (sets of) pads and therefore provide a device according to the invention with a different number of junctions. The  
10 number of junctions in series is determined by the maximum allowable length of the channels, as well as the size and density of junctions.

Preferably, the channels are of such length that significant current flows at reasonable voltages. Currents of 1 pA (pico Ampere) can easily be measured using devices designed and sold by the inventor and his  
15 collaborators. Voltages below 2 Volts can be applied to the electrodes at the ends of the channel without fear of electrolysis, and much larger voltages may be possible for example if they have brief duration, or time integrals of (nearly) zero. Thus, combining the mentioned current and voltage the channel may have a resistance of  $10^{11}$  Ohms. The voltage on the pads  
20 can be very large (e.g., even hundreds of volts) and thus a large dynamic range of 'fixed' charge is practical. It should be noted that the invention is not limited to these values and other currents, voltages and resistances are likewise possible in a device according to the invention.

The charge or voltage on the pads can be changed in time, thus  
25 generating a time-dependent modulation of the doping profile in a device according to the invention. The doping profile of a device according to the invention may not only be varied as a function of time, but also in space, for example by moving the location of transitions in charge. Also, by switching the charge at different pads at different times, a wave of doping can (in  
30 effect) be made that will can sweep charge carriers (of the appropriate sign)

through space. The transitions to be moved can for example be transitions from negative to positive charge or vice versa (such as between the pad 15a and the pad 15b in FIG. 6), which are from hereon also referred to a PN-junctions, or transitions in the concentration of charge, e.g. P-P++ transitions. For instance in the example of FIG. 7, by appropriate changes of the charge or voltage on the pads 15a-15c, the position of the p-n or n-p junctions can be moved. Current carriers in the channel that remain preferentially in the PN junction area (or, oppositely, outside the area) will then be swept along, allowing spatial translocation, i.e., pumping. If the location of changes in sign is varied in a suitable alternating manner or irregularly, mixing will occur. If the channel is built with branches, as in the example of FIG. 4, and pads are placed just below the nodes of those branches, the flow of current carriers can be switched from one branch to another. Switching of the charge carrier flow in the channels can thus be controlled, i.e. using the control circuit of FIG. 3, by changing the voltage or charge on the pads. The fluid will move along with the charge carriers, especially if the charge carriers are ions, and so besides ion flow solvent flow and bulk flow can be controlled this way as well.

The spatial and temporal control of the doping profile may be combined, whereby spatio-temporal waves of doping can be created, with PN junctions moving through space that can sweep charge carriers through space. Likewise, sets of a plurality of junctions, for instance NPN devices (and thus transistors) may be moved in similar manner. Such propagating devices will sweep charge carriers along. Thus a pumping is obtained of charge carriers, of water (which is dragged along with the charge carriers), and of other solutes, dragged along as well. For example by including dyes in the ionic solution in the channel, the device may be used as an electro-optical device.

A device according to the invention may be used to exploit chemical differences of charge carriers not found in known semiconductor devices.

The current flow in semiconductors is, more or less, restricted to two types of quasiparticles, e.g. holes and electrons. Current flow in ionic solutions is carried by a wide range of ions. Spherical metallic ions (e.g.,  $\text{Li}^+$ ,  $\text{Na}^+$ ,  $\text{K}^+$ , etc;  $\text{Ca}^{++}$ ,  $\text{Ba}^{++}$ , etc) have a wide range of diameters and properties; ionic organic compounds offer an large number of possibilities: any soluble organic acid or base provide a new pair of charge carriers. Since each of those charge carriers behave differently in an electrical field, for example because of differences in mass, dipole moment or otherwise, the charge carriers may for example be electrically filtered or specific chemical reactions may be performed.

FIG. 8 shows an example of a device according to the invention which is especially suited for performing chemical reactions or catalysis. On the inner surface 13 of the wall 12 lies a suitable chemical reactant or catalyst 20. The reactant or catalyst 20 in use is within the electrical field of one or more of the pads 15. The electrical field caused by the charge on the pads 15 changes the electrochemical potential of reactants and products in the channel. Thus, by changing the charge on the pad, the electrochemical potential may be changed above or below the activation energy of the respective chemical compound, thus enabling or inhibiting a chemical reaction or catalysis. This is similar to the way the charge of the dopant in a solid state semiconductor influences generation and recombination of charge carriers or how a fixed charge on an amino acid residue changes the local electrical potential and thus the ionization state of nearby weak acid amino acids [17-20]. For example, enzymes may be used as catalysts and reactants resulting from the catalysis may diffuse out of the catalyst to the location through the channel. The reactants may then diffuse in the channel or the wall of the channel may be made of a permeable material such that (some of ) the reactants diffuse out of the channel, for example into another channel.

An electronic device according to the invention may be used to separate chemical compounds in the channel, such as different ion types in

the fluid. An electronic device according to the invention is particularly suited to separate chemical compounds because a large number of junctions can be placed in series. Thus, even a small separation or selectivity in the channel at one pad can be converted into large overall separation.

5 Control of the selectivity is possible because the selectivity between different ion types in a device according to the invention is controlled by a fixed charge density, which in a device according to the invention is controlled by the charge or voltage on the pads and hence controllable, for example by a computer as in the example of FIG. 3. To increase the  
10 selectivity performance, an aqueous ion exchanger may be put into the channel, preferably with a charge density as high as possible. An example of such an ion exchanger is polyglutamic acid. The carboxylate groups of this polymer are dissolved into the aqueous environment and occupy space otherwise occupied by ions and water.

15 In FIG. 10, a device according to the invention with a annular channel is shown which is especially suited for separating compounds with different densities. The device has a channel inlet 16 via which a fluid may be injected in the device. The device also has a channel outlet 16' for transporting the fluid in the channel interior 14 further. An annular device  
20 may for example be used to centrifuge the fluid, thus separating heavy and light compounds in the fluid. By appropriate control of the pads 15 on the inlet 16 and outlet 16', the channel may be closed or opened for specific compounds in the fluid or for the entire fluid. For example, the pads near the outlet and inlet may be positively charged, thus repelling positive ions in  
25 the channel and attracting negative ions and hence forming a filter passing negative ions only.

A device according to the invention may be used in a Programmable Logic Devices (PLD). PLDs are widely used in the electronics industry to build digital circuits. A device according to the invention can be utilized to  
30 build a configured circuit device (CCD). For example, a device according to

the invention can be arranged as a matrix structure and implemented in an integrated circuit structure. By programming the device according to the invention, for example using conventional semiconductor memory elements to drive the control electrodes or pads, parts of the device according to the invention can be configured to be a diode, a pnp or npn transistor, a resistor, or simply an open or a short circuit, which yields to an analog or a digital circuit.

It should be noted that the above-mentioned examples illustrate rather than limit the invention, and that those skilled in the art will be able to design many alternatives without departing from the scope of the appended claims. For example, the control circuit may comprise a suitably programmed general purpose computer connected via a DAC to the contact, a specific electronic circuit or otherwise. Also, if separate pads are set to the same voltage, they may be integrated into a single pad. For instance in the example of FIG. 2, the pads on different walls may be implemented as a single casing of conducting material, locally covering the entire circumference of the channel. Further, in a device according to the invention, the channel may be straight, curved or otherwise. In the claims, any reference signs placed between parentheses shall not be construed as limiting the claim. The word 'comprising' does not exclude the presence of other elements or steps than those listed in a claim. The mere fact that certain measures are recited in mutually different claims does not indicate that a combination of these measures cannot be used to advantage.

## 25 References

1. Shockley, W., *Electrons and Holes in Semiconductors to Applications in Transistor Electronics*. 1950, New York: van Nostrand. 558.

2. Van Roosbroeck, W., Theory of Flow of Electrons and Holes in Germanium and Other Semiconductors. Bell System Technical Journal, 1950. 29: p. 560-607.
3. Bockris, J. and A.M.E. Reddy, Modern Electrochemistry. 1970, New York: Plenum Press. 1432.
4. Conway, B.E., J.O.M. Bockris and E. Yeager, eds. Comprehensive Treatise of Electrochemistry. 1983, Plenum: New York. 472.
5. Newman, J.S., Electrochemical Systems. 2nd ed. 1991, Englewood Cliffs, NJ: Prentice-Hall. 560.
- 10 6. McQuarrie, D.A., Statistical Mechanics. 1976, New York.: Harper and Row.
7. Harned, H.S. and B.B. Owen, The Physical Chemistry of Electrolytic Solutions. Third ed. 1958, New York: Reinhold Publishing Corporation.
- 15 8. Pierret, R.F., Semiconductor Device Fundamentals. 1996, New York: Addison Wesley.
9. Markovitch, P.A., C.A. Ringhofer and C. Schmeiser, Semiconductor Equations. 1990, New York: Springer-Verlag. 248.
10. Rouston, D.J., Bipolar Semiconductor Devices. 1990, New York: McGraw-Hill Publishing Company,.
- 20 11. Sze, S.M., Physics of Semiconductor Devices. 1981, New York: John Wiley & Sons. 838.
12. Hess, K., J.P. Leburton and U. Ravaioli, Computational Electronics: Semiconductor Transport and Device Simulation. 1991, Boston, MA USA: Kluwer. 268.
- 25 13. Jacoboni, C. and P. Lugli, The Monte Carlo Method for Semiconductor Device Simulation. 1989, New York: Springer Verlag.
14. Selberherr, S., Analysis and Simulation of Semiconductor Devices. 1984, New York,: Springer-Verlag. pp. 1-293.

15. Hess, K., *Advanced Theory of Semiconductor Devices*. 2000, New York: IEEE Press. 350.
16. Lundstrom, M., *Fundamentals of Carrier Transport*. 2nd ed. 2000, Cambridge, U.K. ; New York: Cambridge University Press. xix, 418.
- 5 17. Carlson, H.A., J.M. Briggs and J.A. McCammon, Calculation of the Pka Values for the Ligands and Side Chains of Escherichia Coli D-Alanine:D-Alanine Ligase. *J Med Chem*, 1999. 42(1): p. 109-17.
18. McDonald, S.M., R.C. Willson and J.A. McCammon, Determination of the Pka Values of Titratable Groups of an Antigen-Antibody Complex, Hyhel-5-Hen Egg Lysozyme. *Protein Eng*, 1995. 8(9): p. 915-24.
- 10 19. Bastyns, K., M. Froeyen, J.F. Diaz, G. Volckaert and Y. Engelborghs, Experimental and Theoretical Study of Electrostatic Effects on the Isoelectric Ph and the Pka of the Catalytic Residue His-102 of the Recombinant Ribonuclease from *Bacillus Amyloliquefaciens* (Barnase). *Proteins*, 1996. 24(3): p. 370-8.
- 15 20. Honig, B. and A. Nichols, Classical Electrostatics in Biology and Chemistry. *Science*, 1995. 268: p. 1144-1149.

Claims

1. An electronic device, comprising:  
at least one channel with  
5 a fluid fillable channel interior and  
an electrically insulating wall surrounding at least partially the  
channel interior, which channel interior, in use, contains charge  
carriers,  
which electronic device further comprises:  
10 at one control electrode, which electrode is electrically isolated from  
the channel interior and in capacitive contact with the channel  
interior.
2. An electronic device as claimed in claim 1, wherein the at least one  
15 channel in use contains a liquid in which charge carriers are present.
- 3 An electronic device as claimed in claim 1 or 2, wherein the charge  
carriers include ions.
- 20 4. An electronic device as claimed in claim 2 or claims 2 and 3, wherein  
the liquid is an aqueous solution.
5. An electronic device as claimed in claim 3 and 4, wherein the ions  
include salt ions.  
25
6. An electronic device as claimed in claim 1, wherein the charge  
carriers include electrons.
7. An electronic device as claimed in any one of the preceding claims,  
30 wherein the at least one channel has:



a channel inlet, and  
a channel outlet, at which channel inlet and outlet control electrodes are  
provided, which control electrodes are each electrically connected to a  
control device arranged for controlling electrical properties of the channel  
5 inlet and outlet.

8. An electronic device as claimed in any one of the preceding claims,  
comprising at least two parallel channels.

10 9. An electronic device as claimed in claims 8 and any one of claims 1-7,  
wherein two parallel channels are connected by at least one cross channel.

10. An electronic device as claimed in any one of claims 1-9, wherein at  
least two of the control electrodes are positioned facing each other on  
15 opposite sides of the channel.

11. An electronic device as claimed in claim 10, wherein said at least two  
facing control electrodes are electrically connected to each other

20 12. An electronic device as claimed in any one of claims 1-11, wherein at  
least two of the control electrodes are electrically insulated from each other.

13. An electronic device as claimed in any one of claims 1-12, further  
comprising a control device, communicatively connected to the control  
25 electrodes, which control device is arranged for controlling electrical  
properties of the electrodes.

14. An electronic device as claimed in claim 13, wherein the control  
device includes a software programmable apparatus.

15. An electronic device as claimed in any one of the preceding claims, further including at least one direct electrode in conductive contact with the channel interior.
- 5 16. An electronic device as claimed in claim 9, wherein said cross channel is situated between two adjacent electrodes of at least one of said channels as seen in the longitudinal direction of said channels.
- 10 17. An electronic device as claimed in any one of the preceding claims, wherein at least one of said electrodes is a gate electrode.
18. An electronic device as claimed in any one of the preceding claims, wherein at least one channel has a rectangular shaped cross-section.
- 15 19. An electronic device as claimed in any one of the preceding claims, wherein at least one channel is a substantially straight channel.
20. An electronic device as claimed in any one of the claims 1-18, wherein at least one channel has a curved shape.
- 20 21. An electronic device as claimed in claim 20, wherein said channel has an annular shape.
22. An electronic device as claimed in any one of the preceding claims, further comprising: a catalyst or reactant material on the electrically  
25 insulating wall in said channel interior, which material in use lies within an electrical field of at least one of the electrodes.
23. An electronic device as claimed in any one of the preceding claims,  
30 wherein at least a part of the electrically insulating wall contains a

permeable material through which permeable material a reaction or catalysis product can diffuse out of said channel.

24. An electronic device as claimed in any one of the preceding claims,  
5 wherein a polyelectrolyte material is present in the channel.

25. An integrated circuit comprising at least one device as claimed in any one of the preceding claims.

10 26. A method for processing a signal, comprising:  
applying a voltage to at least one of said plurality of control electrodes of a device as claimed in any one of claims 1-24 and  
applying a preparation force corresponding to said signal to charge carriers in the channel interior, which force has at least a component in a  
15 longitudinal direction of the channel.

27. A method for transporting a fluid, comprising  
filling a channel of a device as claimed in any one of the claims 1-24 a fluid containing charge carriers and  
20 applying a voltage to at least one of said plurality of control electrodes of said device as claimed in any one of claims 1-24 such that the charge carriers are moved by an electrical field of the at least one control electrode and the charge carriers transfer at least a part of their energy to kinetic energy of the fluid.

25

28. A method for separating compounds in a fluid, comprising:  
filling a device as claimed in any one of claims 1-24 with a fluid containing charge carriers with positive and negative charges;  
applying a positive voltage to at least one first control electrode of the  
30 device;

applying a negative voltage to at least one second control electrode of the device.

29. A method for preparing a fluid comprising filling at least one  
5 channel of a device as claimed in any one of claims 1-24 with a fluid and  
controlling the control electrode in such a manner that a difference in  
voltage moves along the length of the channel.

30. A method for mixing at least two fluids, comprising  
10 filling at least one channel of a device as claims in any one of claims 1-24  
with a first fluid and a second fluid applying a voltage to at least one control  
electrode, and alternating the voltage on at least one of said control  
electrodes.

15 31. A method for producing a chemical reaction, comprising:  
filling a channel of a device as claimed in any one of claims 1-24 with a  
suitable reactant and  
applying a voltage to at least one control electrode of the device, such that  
the electrochemical energy of the reactant is increased to at least the  
20 activation energy of the reactant.

32. A control device for controlling at least one of the control electrodes of  
an electronic device as claimed in any one of claims 1-24.

25 33. A computer program product, comprising program code for  
performing steps of a method as claimed in any one of claims 26-31 when  
run on a programmable device.

Fig. 1

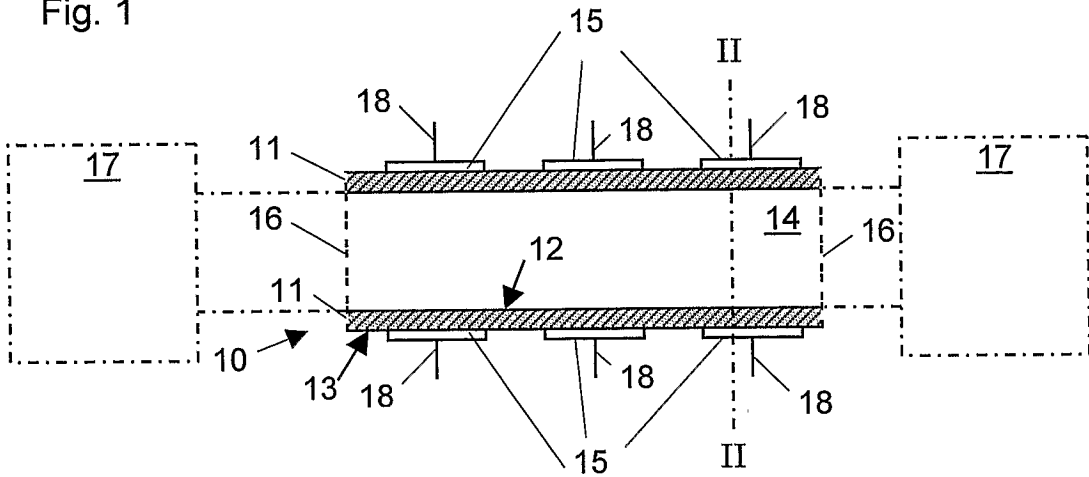

Fig. 2

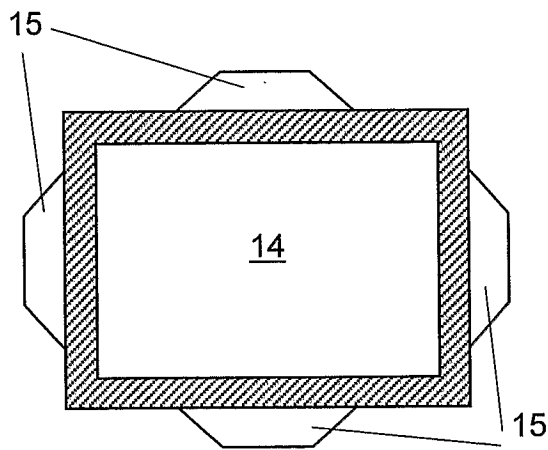

Fig. 4

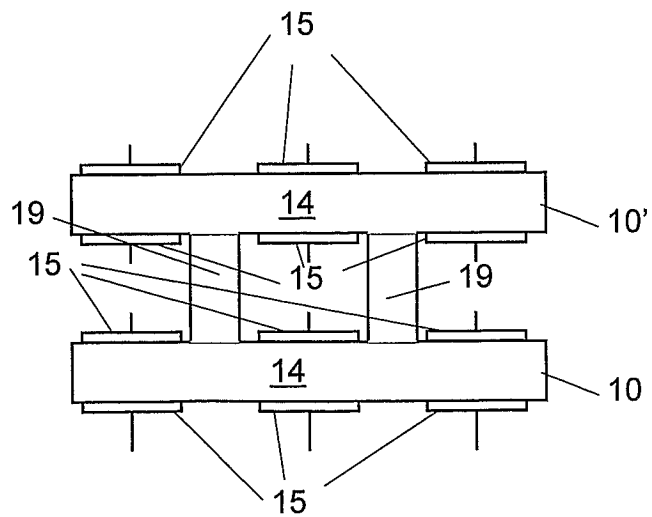

Fig. 3

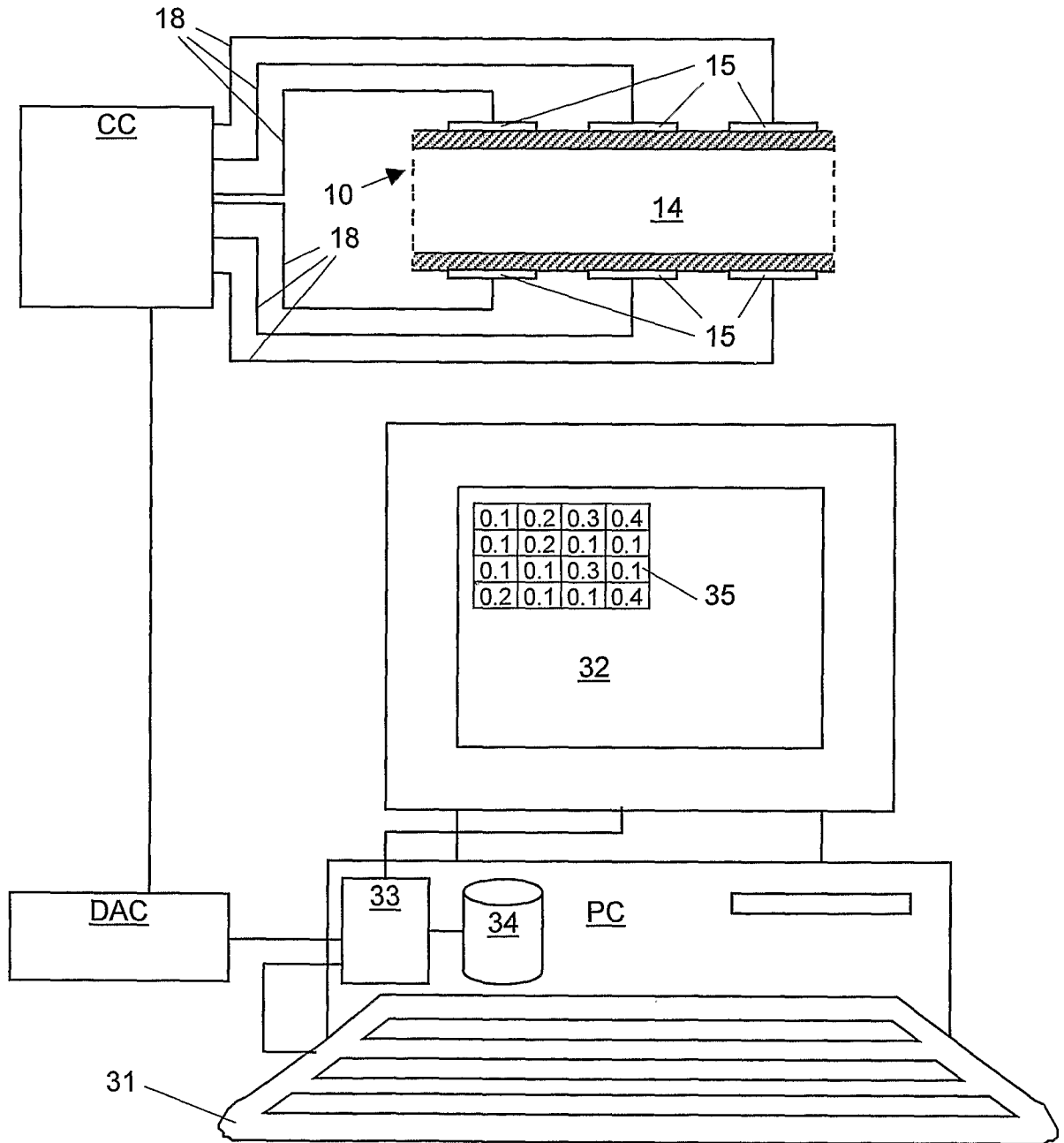

Fig. 5

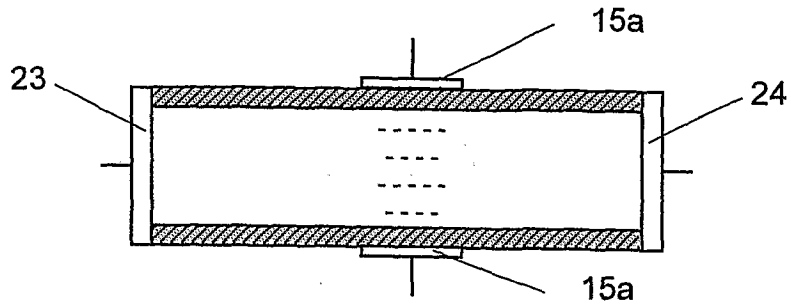

Fig. 6

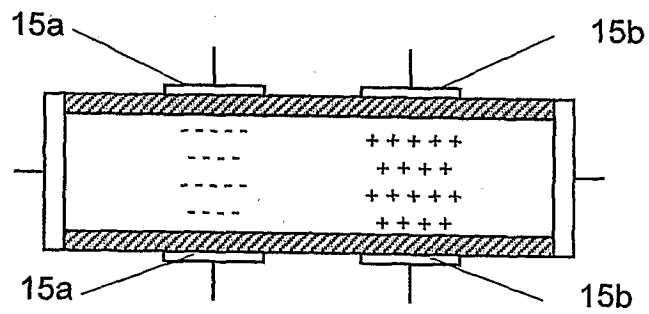

Fig. 7

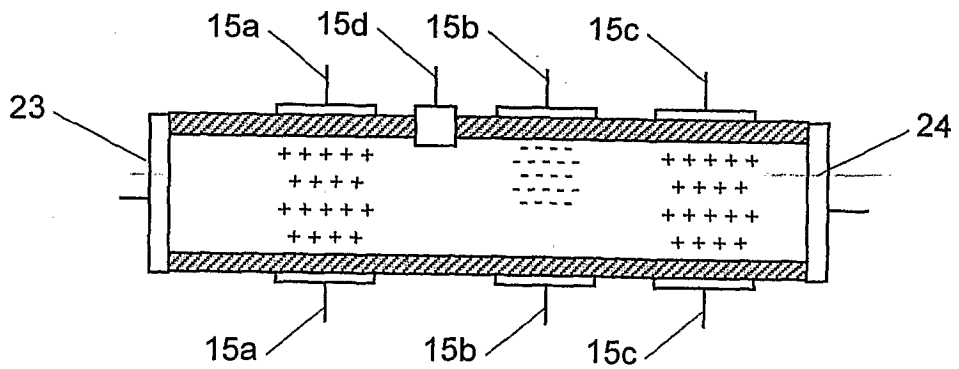

Fig. 8

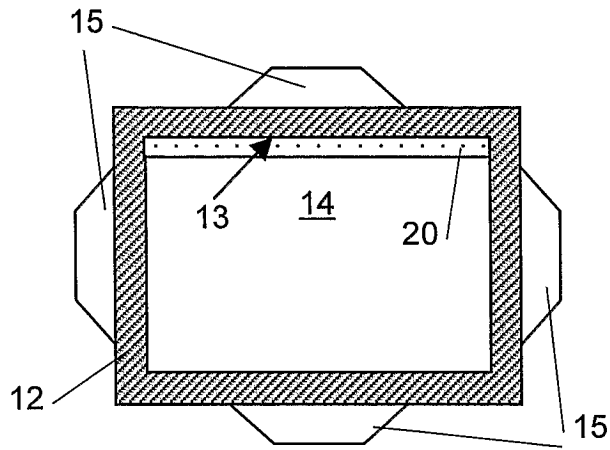

Fig. 9

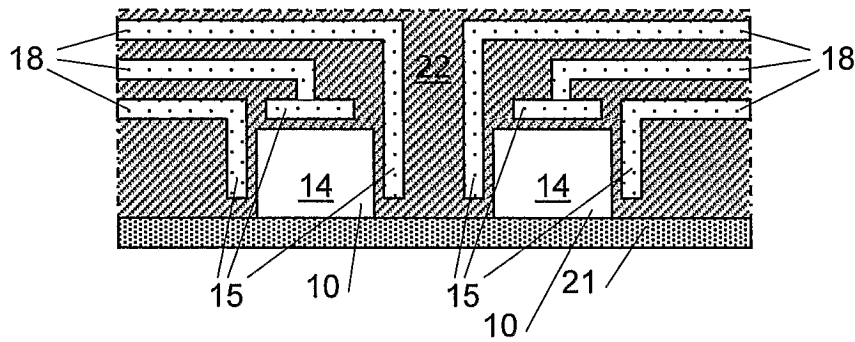
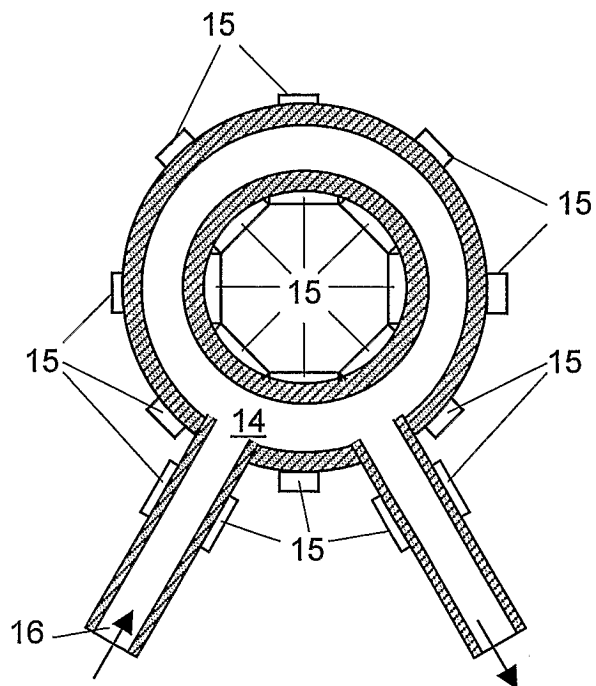

Fig. 10





## INTERNATIONAL SEARCH REPORT

PCT/NL 03/00013

A. CLASSIFICATION OF SUBJECT MATTER  
IPC 7 H01G9/00

According to International Patent Classification (IPC) or to both national classification and IPC

## B. FIELDS SEARCHED

Minimum documentation searched (classification system followed by classification symbols)

IPC 7 H01L H01G

Documentation searched other than minimum documentation to the extent that such documents are included in the fields searched

Electronic data base consulted during the international search (name of data base and, where practical, search terms used)

EPO-Internal, INSPEC, PAJ, COMPENDEX

## C. DOCUMENTS CONSIDERED TO BE RELEVANT

Category °	Citation of document, with indication, where appropriate, of the relevant passages	Relevant to claim No.
X	US 2002/163829 A1 (MANDELL AARON ET AL) 7 November 2002 (2002-11-07)  figures 1-3 ---	1-3, 5, 10-12, 15, 17, 26, 28
X	US 4 435 742 A (HETRICK ROBERT E) 6 March 1984 (1984-03-06) figures 7-13 ---	1, 24, 27, 29-31
X	US 3 273 027 A (JOOST BATELAAN ET AL) 13 September 1966 (1966-09-13) column 5, line 7 - line 27; figure 6 --- -/--	1-4, 7, 10, 19-21

 Further documents are listed in the continuation of box C. Patent family members are listed in annex.

## ° Special categories of cited documents :

- \*A\* document defining the general state of the art which is not considered to be of particular relevance
- \*E\* earlier document but published on or after the international filing date
- \*L\* document which may throw doubts on priority claim(s) or which is cited to establish the publication date of another citation or other special reason (as specified)
- \*O\* document referring to an oral disclosure, use, exhibition or other means
- \*P\* document published prior to the international filing date but later than the priority date claimed

- \*T\* later document published after the international filing date or priority date and not in conflict with the application but cited to understand the principle or theory underlying the invention
- \*X\* document of particular relevance; the claimed invention cannot be considered novel or cannot be considered to involve an inventive step when the document is taken alone
- \*Y\* document of particular relevance; the claimed invention cannot be considered to involve an inventive step when the document is combined with one or more other such documents, such combination being obvious to a person skilled in the art.
- \*Z\* document member of the same patent family

Date of the actual completion of the international search

8 October 2003

Date of mailing of the international search report

15/10/2003

Name and mailing address of the ISA

European Patent Office, P.B. 5618 Patentlaan 2  
NL - 2280 HV Rijswijk  
Tel. (+31-70) 340-2040, Tx. 31 651 epo nl,  
Fax: (+31-70) 340-3016

Authorized officer

Königstein, C

## INTERNATIONAL SEARCH REPORT

PCT/NL 03/00013

C.(Continuation) DOCUMENTS CONSIDERED TO BE RELEVANT		
Category *	Citation of document, with indication, where appropriate, of the relevant passages	Relevant to claim No.
X	NILSSON D ET AL: "BI-STABLE AND DYNAMIC CURRENT MODULATION IN ELECTROCHEMICAL ORGANIC TRANSISTORS" ADVANCED MATERIALS, VCH VERLAGSGESELLSCHAFT, WEINHEIM, DE, vol. 14, no. 1, 4 January 2002 (2002-01-04), pages 51-54, XP001129569 ISSN: 0935-9648 the whole document	1,4,6,7, 13,14,20
X	POPKIROV G ST: "CAPACITANCE MEASUREMENT OF SEMICONDUCTOR ELECTRODES BY MEANS OF THEHP-4274A LCR METER" REVIEW OF SCIENTIFIC INSTRUMENTS, AMERICAN INSTITUTE OF PHYSICS. NEW YORK, US, vol. 61, no. 1, PART 1, 1990, pages 200-202, XP000101234 ISSN: 0034-6748 the whole document	32
A	the whole document	1,13,14
X	RANI V SANTHANAM K S V: "Polycarbazole-based electrochemical transistor" JOURNAL OF SOLID STATE ELECTROCHEMISTRY, SPRINGER, BERLIN,, DE, vol. 2, no. 2, 1998, pages 99-101, XP002954506 ISSN: 1432-8488 figure 1	1-3
X	KRUEGER M ET AL: "ELECTROCHEMICAL CARBON NANOTUBE FIELD-EFFECT TRANSISTOR" APPLIED PHYSICS LETTERS, AMERICAN INSTITUTE OF PHYSICS. NEW YORK, US, vol. 78, no. 9, 26 February 2001 (2001-02-26), pages 1291-1293, XP001020605 ISSN: 0003-6951 the whole document	1
X	US 1 769 837 A (HULL ALBERT W) 1 July 1930 (1930-07-01) the whole document	1
A	US 5 946 185 A (FULTON JAMES THOMAS) 31 August 1999 (1999-08-31) the whole document	1,23

**INTERNATIONAL SEARCH REPORT**

PCT/NL 03/00013

**Box I Observations where certain claims were found unsearchable (Continuation of item 1 of first sheet)**

This International Search Report has not been established in respect of certain claims under Article 17(2)(a) for the following reasons:

1.  Claims Nos.: 33  
because they relate to subject matter not required to be searched by this Authority, namely:  
Rule 39.1(vi) PCT - Program for computers
2.  Claims Nos.:  
because they relate to parts of the International Application that do not comply with the prescribed requirements to such an extent that no meaningful International Search can be carried out, specifically:
3.  Claims Nos.:  
because they are dependent claims and are not drafted in accordance with the second and third sentences of Rule 6.4(a).

**Box II Observations where unity of invention is lacking (Continuation of item 2 of first sheet)**

This International Searching Authority found multiple inventions in this international application, as follows:

1.  As all required additional search fees were timely paid by the applicant, this International Search Report covers all searchable claims.
2.  As all searchable claims could be searched without effort justifying an additional fee, this Authority did not invite payment of any additional fee.
3.  As only some of the required additional search fees were timely paid by the applicant, this International Search Report covers only those claims for which fees were paid, specifically claims Nos.:
4.  No required additional search fees were timely paid by the applicant. Consequently, this International Search Report is restricted to the invention first mentioned in the claims; it is covered by claims Nos.:

**Remark on Protest**

- The additional search fees were accompanied by the applicant's protest.
- No protest accompanied the payment of additional search fees.

## INTERNATIONAL SEARCH REPORT

PCT/NL 03/00013

Patent document cited in search report	Publication date	Patent family member(s)	Publication date
US 2002163829 A1	07-11-2002	WO 02091494 A1	14-11-2002
US 4435742 A	06-03-1984	US 4332003 A	25-05-1982
US 3273027 A	13-09-1966	GB 996412 A	30-06-1965
US 1769837 A	01-07-1930	FR 629640 A	14-11-1927
US 5946185 A	31-08-1999	NONE	